

RISER ANGLE BRACKETS COMPONENTS INDEX

PAGE	DATE	"A" HEIGHT	DESCRIPTION
E-1	03/19/21		Riser Angle Brackets Components Index
E-1.1	03/19/21		Riser Angle Brackets Components Index
E-2	06/05/96	450-800 mm	Maximum Recommended Loads
E-3	08/18/03	450-800 mm	Maximum Recommended Loads
E-4	12/02/19	100-400 mm	Riser Angle Bracket
E-4.1	09/24/04	100-400 mm	Riser Angle Bracket
E-5	12/02/19	100-800 mm	Riser Angle Bracket
E-6	09/24/04	100-800 mm	Riser Angle Bracket
E-7	08/13/07	100-400 mm	Riser Angle Bracket
E-8	12/02/19	100-400 mm	Riser Angle Bracket
E-8.1	12/02/19	100-400 mm	Riser Angle Bracket
E-9	12/02/19	450-800 mm	Riser Angle Bracket
E-10	09/24/04	450-800 mm	Riser Angle Bracket
E-11	08/13/07	---	Riser Angle Bracket
E-12	12/02/19	150-500 mm	Stack Riser
E-13	12/02/19	400&800 mm	Stack Riser
E-14	03/01/99	---	Maximum Recommended Loads
E-15	08/18/03	300-500 mm	Maximum Recommended Loads
E-16	08/18/03	550-750 mm	Maximum Recommended Loads
E-17	08/18/03	800-1400 mm	Maximum Recommended Loads
E-18	08/18/03	1450-1600 mm	Maximum Recommended Loads
E-19	08/13/07	---	Tubular Riser Construction
E-20	07/15/03	850-1600	Tubular Riser
E-21	07/15/03	850-1600	Tubular Riser
E-22	09/24/04	850-1600	Tubular Riser
E-23	07/15/03	---	Tubular Riser Maximum Recommended Loads
E-24	10/06/03	850-1600	Tubular Riser Maximum Recommended Loads
E-25	12/02/19	100-400	Riser Angle Bracket - Aluminum
E-26	02/22/22	100-400	Riser Angle Bracket - Aluminum
E-27	08/01/03	100-400	Maximum Recommended Loads
E-28	08/01/03	100-400	Maximum Recommended Loads

RISER ANGLE BRACKETS COMPONENTS INDEX

03/19/21

GLOBAL STANDARD COMPONENTS



Assembly

02/22/22

PAGE	DATE	"A" HEIGHT	DESCRIPTION
E-29	07/09/07	60-600	Riser for Pass Tables
E-30	05/08/07	60-600	Riser for Pass Tables
E-31	03/19/21	300-1200mm	Drop Away Leaf Riser
E-32	03/19/21	600-1500mm	Drop Away Leaf Riser

MAXIMUM RECOMMENDED LOADS

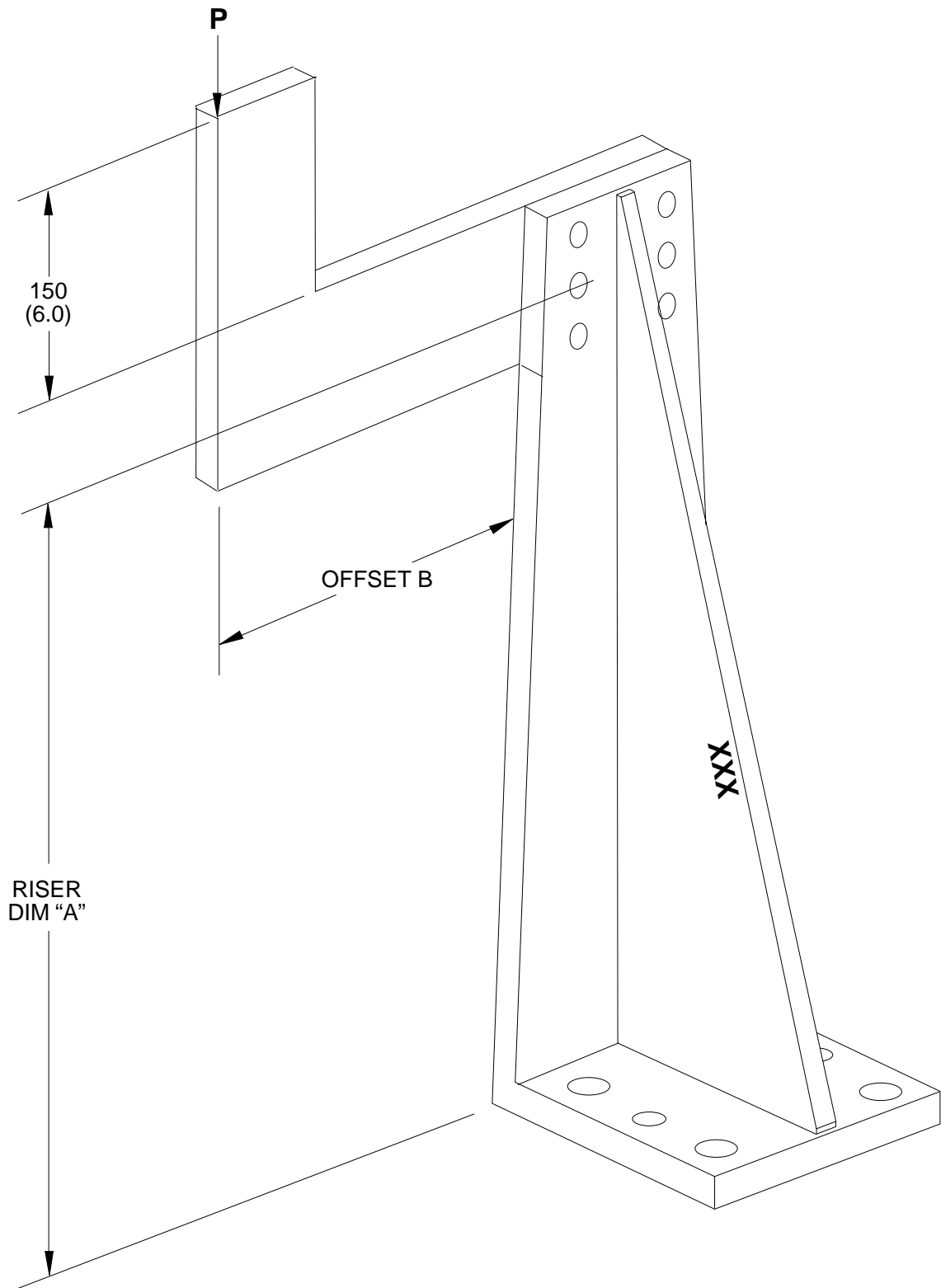

A

SEE TABLE OF RECOMMENDED LOADS ON FOLLOWING PAGE

MAXIMUM RECOMMENDED LOADS

D
C
A

B

MAXIMUM RECOMMENDED LOAD FOR 0.13 mm (0.005 IN) DEFLECTION
 OFFSET VALUES (B) AND POINTS OF APPLICATION OF LOAD P ARE DEFINED IN THE FIGURE ON PAGE E2.
 ALLOWABLE 0.13 mm (0.005 in) DEFLECTIONS ARE MEASURED AT THE POINT OF APPLICATION OF LOAD P, AND DO NOT
 INCLUDE DEFLECTIONS OF THE BLADE.
 MAXIMUM RECOMMENDED LOADS ARE BASED ON STEEL WITH A MODULUS OF ELASTICITY OF 207 GPA (30,000,000 PSI).
 CAST IRON ALLOYS MAY BE USED PROVIDED THEY HAVE A MODULUS OF ELASTICITY OF AT LEAST 165 GPA (24,000,000 PSI).

Riser	Offset B		Load P	
	mm	in.	N	lb
ARA450M & E ARA451M & E	300	12	747	168
	250	10	936	211
	200	8	1,209	272
	150	6	1,600	360
	100	4	2,204	496
ARA500M & E ARA501M & E	300	12	672	151
	250	10	843	190
	200	8	1,088	245
	150	6	1,440	324
	100	4	1,984	446
ARA550M & E ARA551M & E	300	12	611	137
	250	10	766	172
	200	8	989	223
	150	6	1,309	295
	100	4	1,804	406
ARA600M & E ARA601M & E	300	12	560	126
	250	10	702	158
	200	8	907	204
	150	6	1,200	270
	100	4	1,653	372
ARA650M & E ARA651M & E	300	12	521	117
	250	10	653	147
	200	8	837	188
	150	6	1,104	249
	100	4	1,517	341
ARA700M & E ARA701M & E	300	12	486	109
	250	10	606	136
	200	8	773	174
	150	6	1,017	229
	100	4	1,389	312
ARA750M & E ARA751M & E	300	12	454	102
	250	10	564	127
	200	8	716	161
	150	6	937	211
	100	4	1,283	289
ARA800M & E ARA801M & E	300	12	424	95
	250	10	526	118
	200	8	666	150
	150	6	869	195
	100	4	1,184	266

SEE DRAWING ON PRECEDING PAGE

RISER ANGLE BRACKET

GLOBAL STANDARD COMPONENTS



Assembly

12/02/19

Tolerances:

- 1 PLACE MACHINING ± 0.3
- 1 PLACE FABRICATION ± 1.5
- 2 PLACE ± 0.08 BETWEEN MACHINED SURFACES
- ± 0.03 BETWEEN SINGLE DOWEL AND A HEEL SURFACE
- ± 0.03 BETWEEN DOWELS IN THE SAME PLANE
- ± 0.10 BETWEEN DOWELS IN DIFFERENT PLANES
- ± 0.13 TO SCREW HOLES, NON ACCUMULATIVE

NOTES: ALL DIMENSIONS METRIC UNLESS OTHERWISE NOTED.
IDENTIFY WITH NAAMS CODE NUMBER AS SHOWN **XXX**.

MATERIAL: STEEL ASTM A-36
SEE PAGE B-1.1 FOR GLOBAL MATERIALS CHART

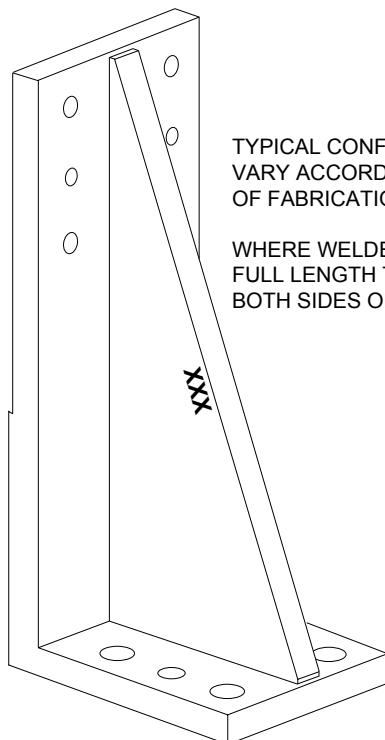
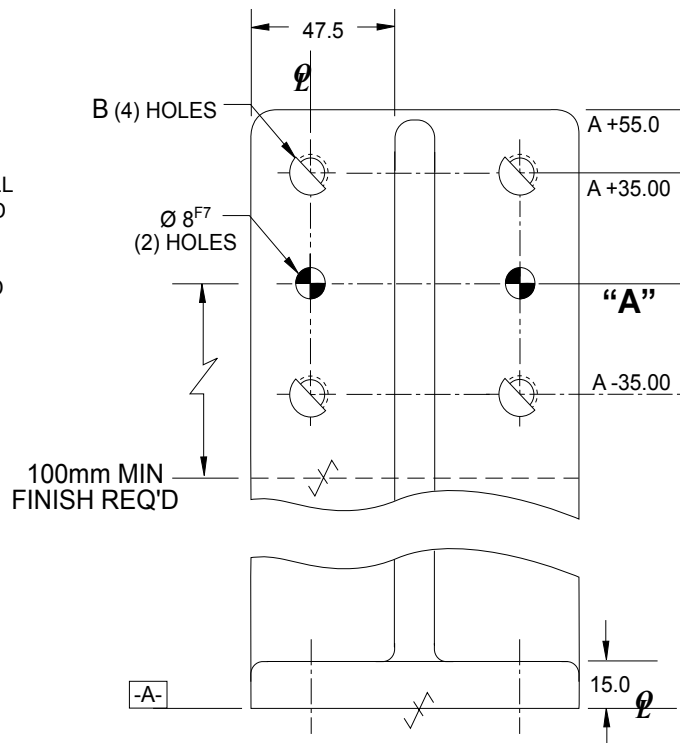
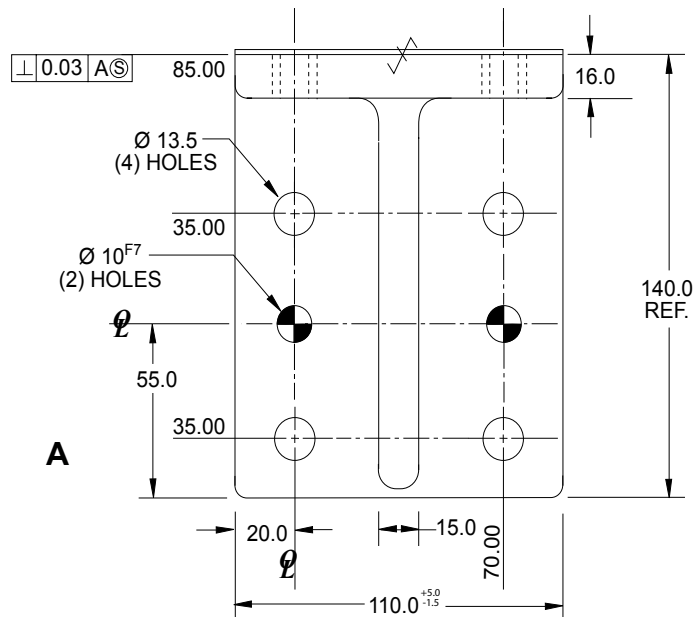
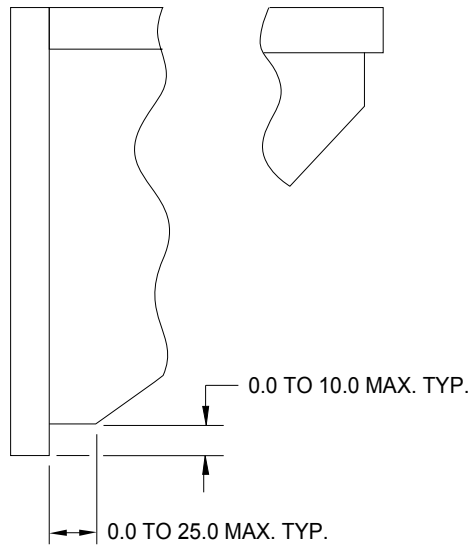

TYPICAL CONFIGURATION. WILL VARY ACCORDING TO METHOD OF FABRICATION

WHERE WELDED, FILLET WELD FULL LENGTH TO AWS D1.1 BOTH SIDES OF JOINT

TABULATED INFORMATION ON FOLLOWING PAGE

G

I

C

B

A

D

F

J

H

E

RISER ANGLE BRACKET

GLOBAL STANDARD COMPONENTS



Assembly

09/24/04

NAMMS CODE	"A" DIM	"B"	WT. kg
AAB100M	100.00	M10x1.5	5.44
AAB101M	100.00	11.0	5.44
AAB150M	150.00	M10x1.5	6.35
AAB151M	150.00	11.0	6.35
AAB200M	200.00	M10x1.5	7.71
AAB201M	200.00	11.0	7.71
AAB250M	250.00	M10x1.5	9.07
AAB251M	250.00	11.0	9.07
AAB300M	300.00	M10x1.5	10.43
AAB301M	300.00	11.0	10.43
AAB350M	350.00	M10x1.5	12.24
AAB351M	350.00	11.0	12.24
AAB400M	400.00	M10x1.5	13.61
AAB401M	400.00	11.0	13.61

A

B

SEE DRAWING ON PRECEDING PAGE

RISER ANGLE BRACKET

GLOBAL STANDARD COMPONENTS

TM **NAAMS**



Assembly

12/02/19

Tolerances:

- 1 PLACE MACHINING ± 0.3
- 1 PLACE FABRICATION ± 1.5
- 2 PLACE ± 0.08 BETWEEN MACHINED SURFACES
 - ± 0.03 BETWEEN SINGLE DOWEL AND A HEEL SURFACE
 - ± 0.03 BETWEEN DOWELS IN THE SAME PLANE
 - ± 0.10 BETWEEN DOWELS IN DIFFERENT PLANES
 - ± 0.13 TO SCREW HOLES, NON ACCUMULATIVE

NOTES: ALL DIMENSIONS METRIC UNLESS OTHERWISE NOTED.
IDENTIFY WITH NAAMS CODE NUMBER AS SHOWN **XXX**.

MAXIMUM RECOMMENDED LOADS ON PAGE E-2

MATERIAL: STEEL ASTM A-36
SEE PAGE B-1.1 FOR GLOBAL MATERIALS CHART

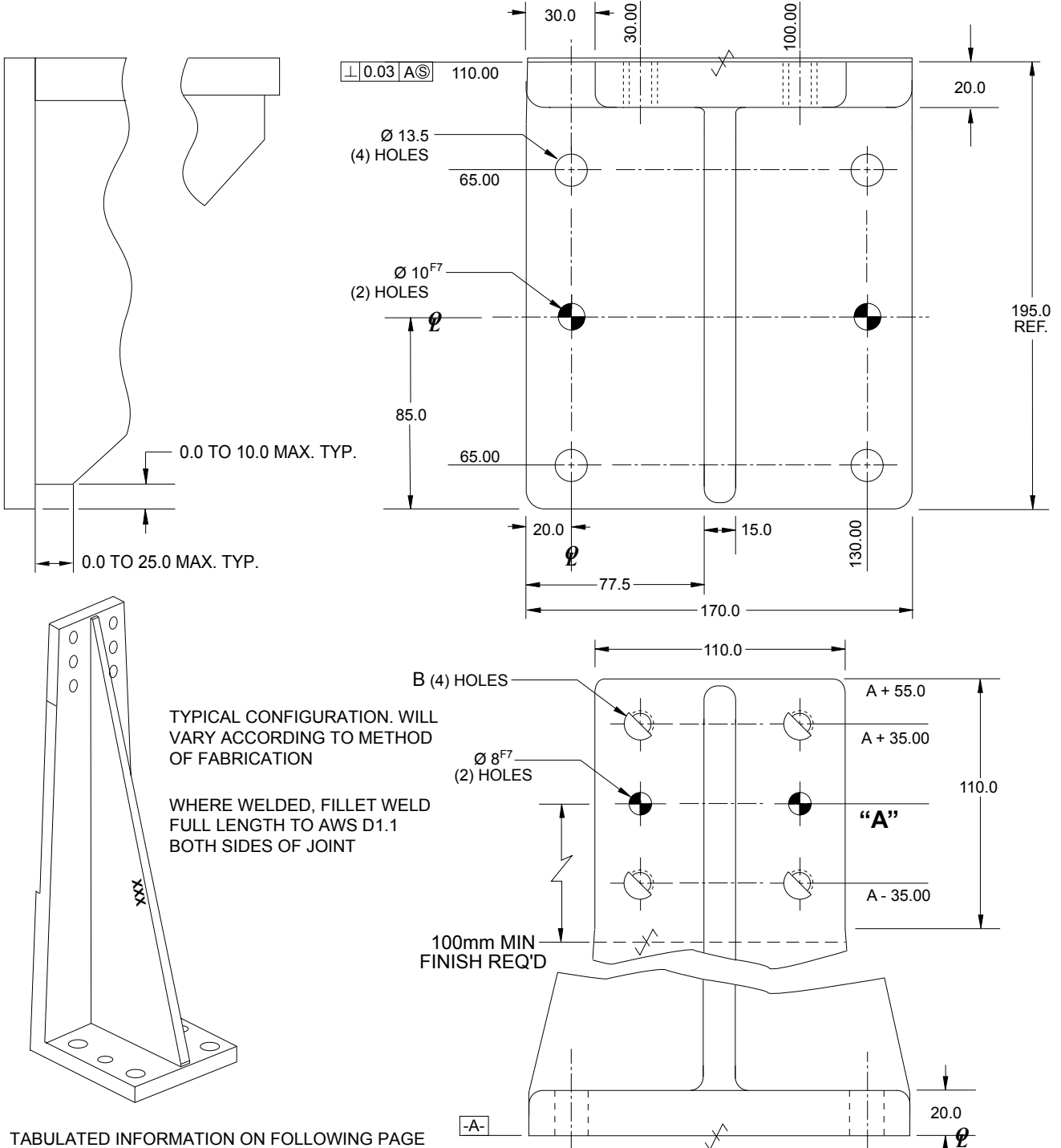

G
F
D
C
B

H

E

A

TABULATED INFORMATION ON FOLLOWING PAGE

RISER ANGLE BRACKET

GLOBAL STANDARD COMPONENTS



Assembly

09/24/04

NAMMS CODE	"A" DIM	"B"	WT. kg
ARA100M	100.00	M10x1.5	9.2
ARA101M	100.00	11.0	9.2
ARA150M	150.00	M10x1.5	11.2
ARA151M	150.00	11.0	11.2
ARA200M	200.00	M10x1.5	13.1
ARA201M	200.00	11.0	13.1
ARA250M	250.00	M10x1.5	14.9
ARA251M	250.00	11.0	14.9
ARA300M	300.00	M10x1.5	16.1
ARA301M	300.00	11.0	16.1
ARA350M	350.00	M10x1.5	18.4
ARA351M	350.00	11.0	18.4
ARA400M	400.00	M10x1.5	19.6
ARA401M	400.00	11.0	19.6
ARA450M	450.00	M10x1.5	24.5
ARA451M	450.00	11.0	24.5
ARA500M	500.00	M10x1.5	28.1
ARA501M	500.00	11.0	28.1
ARA550M	550.00	M10x1.5	29.5
ARA551M	550.00	11.0	29.5
ARA600M	600.00	M10x1.5	31.7
ARA601M	600.00	11.0	31.7
ARA650M	650.00	M10x1.5	34.5
ARA651M	650.00	11.0	34.5
ARA700M	700.00	M10x1.5	37.2
ARA701M	700.00	11.0	37.2
ARA750M	750.00	M10x1.5	39.0
ARA751M	750.00	11.0	39.0
ARA800M	800.00	M10x1.5	44.4
ARA801M	800.00	11.0	44.4

A

B

C

SEE DRAWING ON PRECEDING PAGE

RISER ANGLE BRACKET

GLOBAL STANDARD COMPONENTS



Assembly

08/13/07

Tolerances:

- 1 PLACE MACHINING ± 0.3
- 1 PLACE FABRICATION ± 1.5
- 2 PLACE ± 0.08 BETWEEN MACHINED SURFACES
- ± 0.03 BETWEEN SINGLE DOWEL AND A HEEL SURFACE
- ± 0.03 BETWEEN DOWELS IN THE SAME PLANE
- ± 0.10 BETWEEN DOWELS IN DIFFERENT PLANES
- ± 0.13 TO SCREW HOLES, NON ACCUMULATIVE

✓ SURFACES TO BE FLAT, PARALLEL & PERPENDICULAR TO WITHIN 0.015 T.I.R.
 NOTES: ALL DIMENSIONS METRIC UNLESS OTHERWISE NOTED.

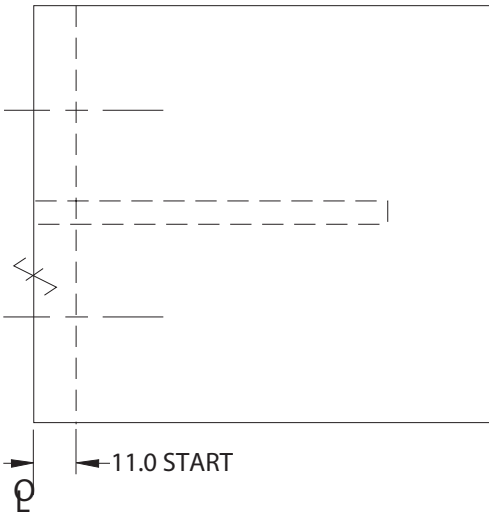

NAMMS CODE	"A" DIM	WT. kg
AHB001M	11.0	2.5
AHB002M	M10 x 1.5	2.5

MATERIAL: STEEL ASTM A-36
 SEE PAGE B-1.1 FOR GLOBAL MATERIALS CHART

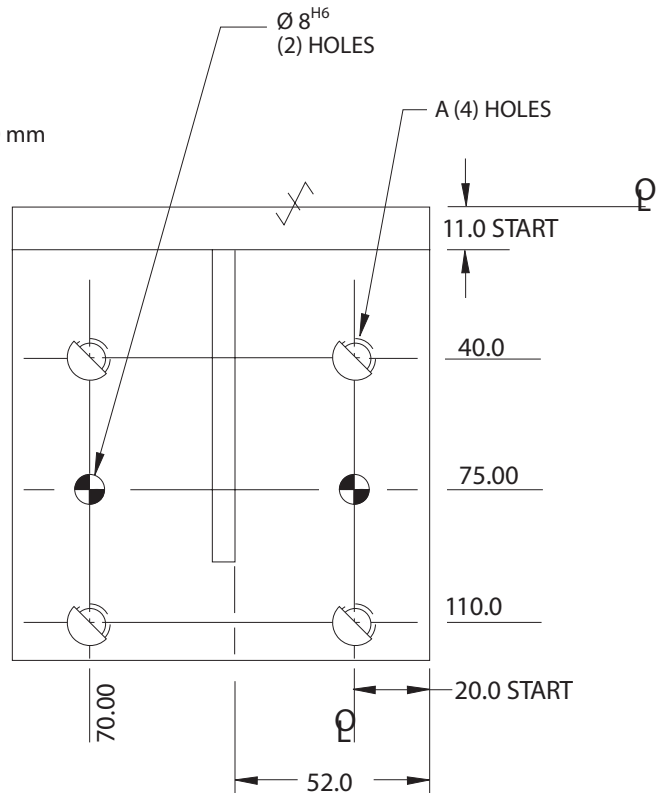
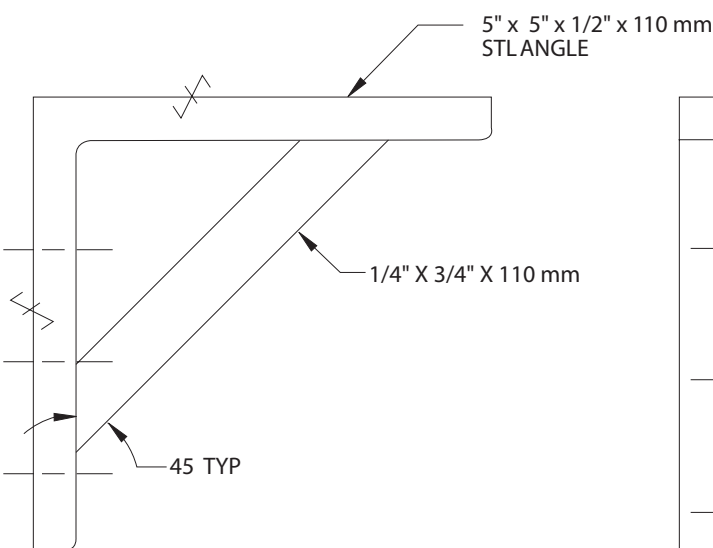

C

D

F

A

E

B

RISER ANGLE BRACKET

GLOBAL STANDARD COMPONENTS

TM **NAAMS**



Assembly

12/02/19

Tolerances:

- 1 PLACE MACHINING ± 0.3
- 1 PLACE FABRICATION ± 1.5
- 2 PLACE ± 0.08 BETWEEN MACHINED SURFACES
- ± 0.03 BETWEEN SINGLE DOWEL AND A HEEL SURFACE
- ± 0.03 BETWEEN DOWELS IN THE SAME PLANE
- ± 0.10 BETWEEN DOWELS IN DIFFERENT PLANES
- ± 0.13 TO SCREW HOLES, NON ACCUMULATIVE

NOTES: ALL DIMENSIONS METRIC UNLESS OTHERWISE NOTED.
IDENTIFY WITH NAAMS CODE NUMBER AS SHOWN **XXX**.

MATERIAL: STEEL ASTM A-36
SEE PAGE B-1.1 FOR GLOBAL MATERIALS CHART

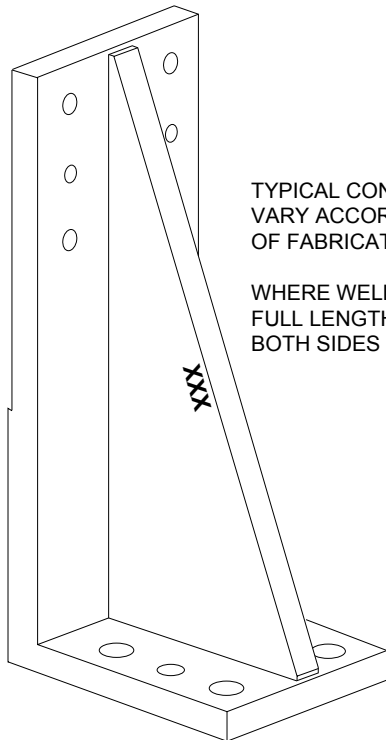
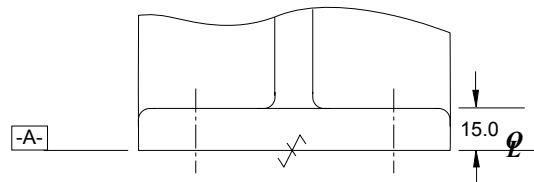
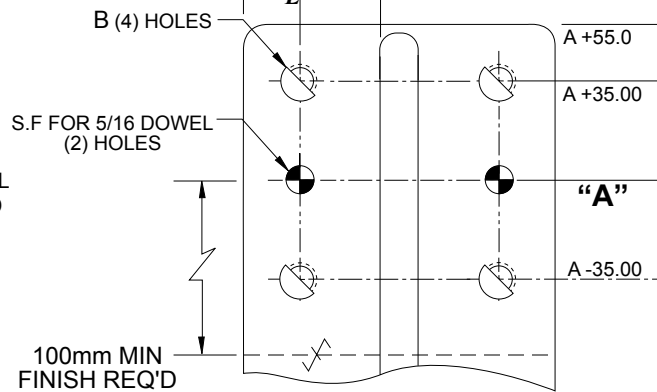
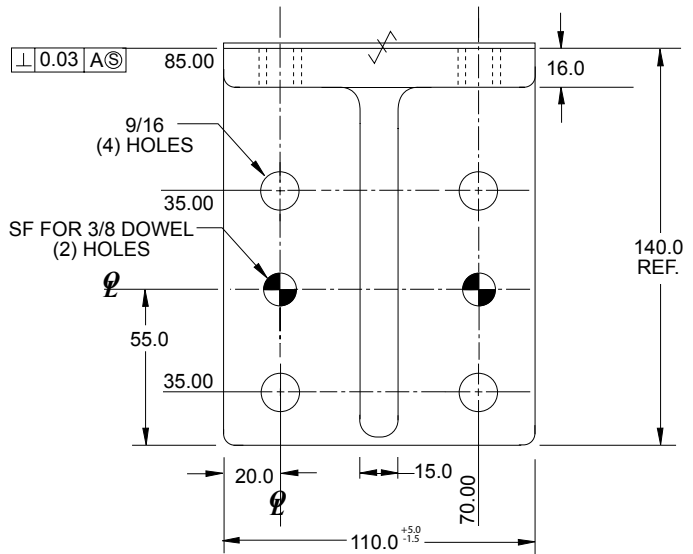
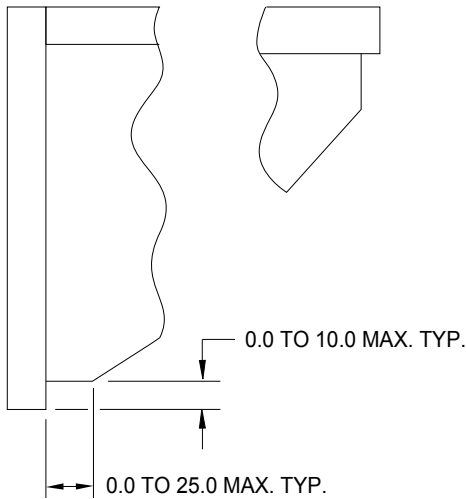

TYPICAL CONFIGURATION. WILL VARY ACCORDING TO METHOD OF FABRICATION

WHERE WELDED, FILLET WELD FULL LENGTH TO AWS D1.1 BOTH SIDES OF JOINT

E

H

C

B

A

D

G

I

F

RISER ANGLE BRACKET

GLOBAL STANDARD COMPONENTS



Assembly

12/02/19

NAAMS CODE	"A" DIM	B	WT. kg
AAB100E	100.00	3/8-16 tap	5.44
AAB101E	100.00	13/32	5.44
AAB150E	150.00	3/8-16 tap	6.35
AAB151E	150.00	13/32	6.35
AAB200E	200.00	3/8-16 tap	7.71
AAB201E	200.00	13/32	7.71
AAB250E	250.00	3/8-16 tap	9.07
AAB251E	250.00	13/32	9.07
AAB300E	300.00	3/8-16 tap	10.43
AAB301E	300.00	13/32	10.43
AAB350E	350.00	3/8-16 tap	12.24
AAB351E	350.00	13/32	12.24
AAB400E	400.00	3/8-16 tap	13.61
AAB401E	400.00	13/32	13.61

RISER ANGLE BRACKET

GLOBAL STANDARD COMPONENTS



Assembly

12/02/19

Tolerances:

- 1 PLACE MACHINING ± 0.3
- 1 PLACE FABRICATION ± 1.5
- 2 PLACE ± 0.08 BETWEEN MACHINED SURFACES
- ± 0.03 BETWEEN SINGLE DOWEL AND A HEEL SURFACE
- ± 0.03 BETWEEN DOWELS IN THE SAME PLANE
- ± 0.10 BETWEEN DOWELS IN DIFFERENT PLANES
- ± 0.13 TO SCREW HOLES, NON ACCUMULATIVE

NOTES: ALL DIMENSIONS METRIC UNLESS OTHERWISE NOTED.
IDENTIFY WITH NAAMS CODE NUMBER AS SHOWN **XXX**.

MAXIMUM RECOMMENDED
LOADS ON PAGE E-2

MATERIAL: STEEL ASTM A-36
SEE PAGE B-1.1 FOR GLOBAL
MATERIALS CHART

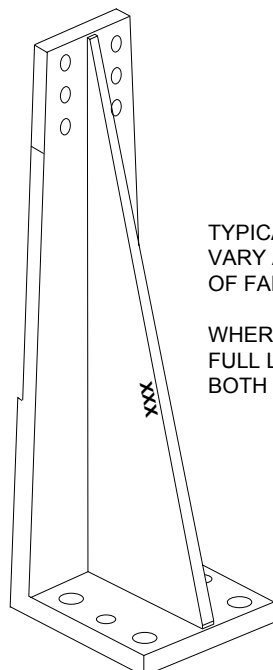
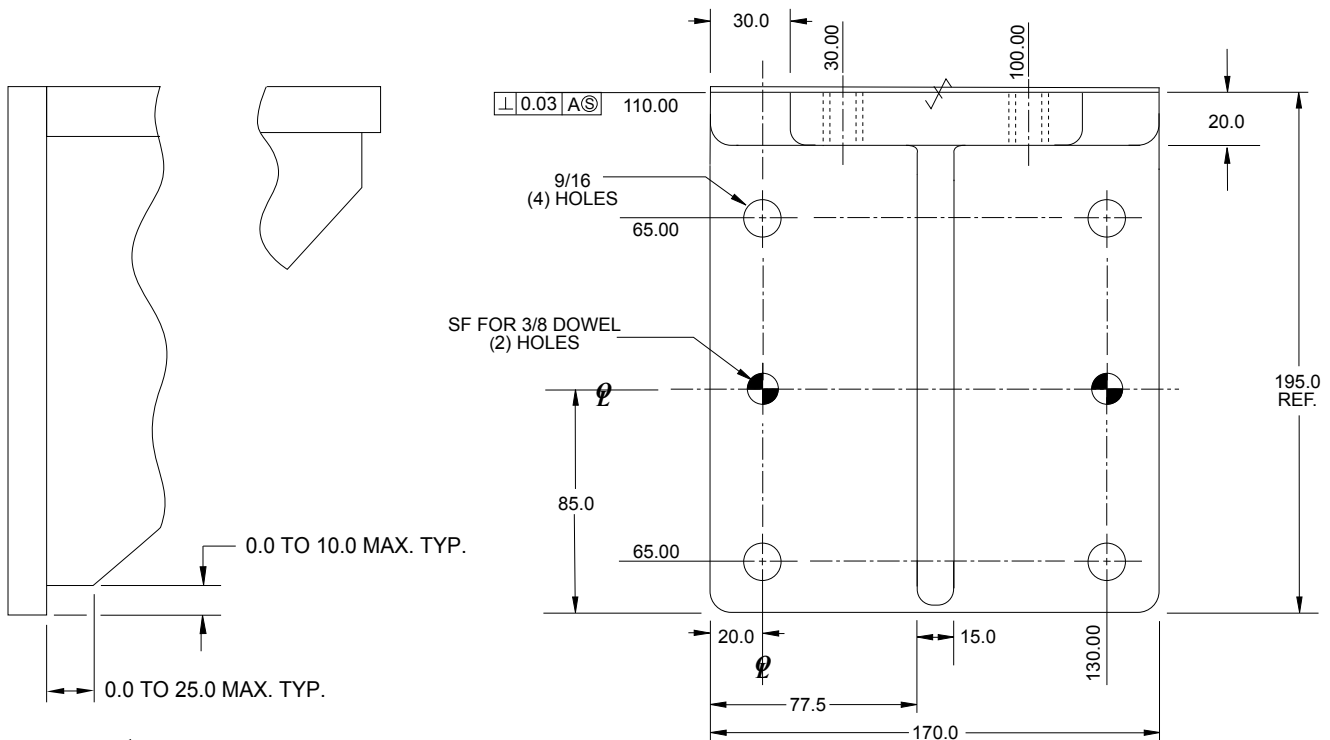

TYPICAL CONFIGURATION. WILL VARY ACCORDING TO METHOD OF FABRICATION

WHERE WELDED, FILLET WELD FULL LENGTH TO AWS D1.1 BOTH SIDES OF JOINT

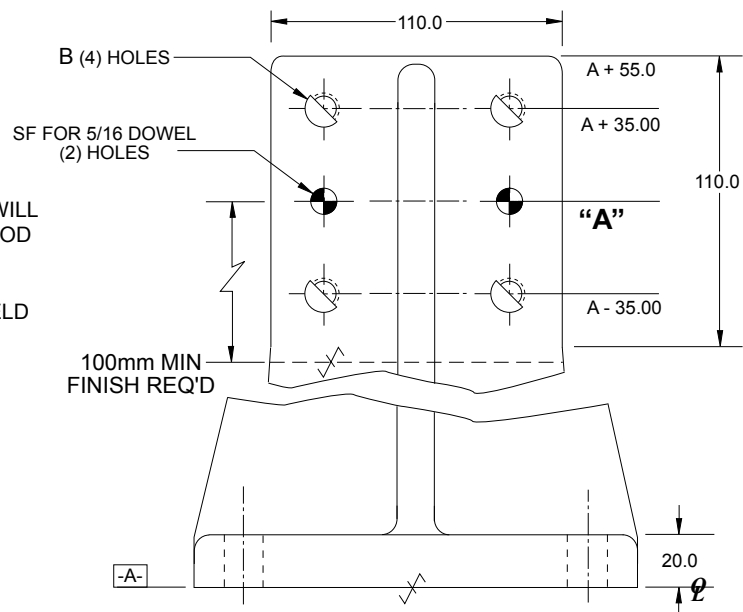

TABULATED INFORMATION ON FOLLOWING PAGE

D

G

H

E

C

B

I

F

A

C

RISER ANGLE BRACKET

GLOBAL STANDARD COMPONENTS



Assembly

09/24/04

NAMMS CODE	"A" DIM	"B"	WT. kg
ARA450E	450.00	3/8-16 tap	24.5
ARA451E	450.00	13/32	24.5
ARA500E	500.00	3/8-16 tap	28.1
ARA501E	500.00	13/32	28.1
ARA550E	550.00	3/8-16 tap	29.5
ARA551E	550.00	13/32	29.5
ARA600E	600.00	3/8-16 tap	31.7
ARA601E	600.00	13/32	31.7
ARA650E	650.00	3/8-16 tap	34.5
ARA651E	650.00	13/32	34.5
ARA700E	700.00	3/8-16 tap	37.2
ARA701E	700.00	13/32	37.2
ARA750E	750.00	3/8-16 tap	39.0
ARA751E	750.00	13/32	39.0
ARA800E	800.00	3/8-16 tap	44.4
ARA801E	800.00	13/32	44.4

A

B

C

SEE DRAWING ON PRECEDING PAGE

RISER ANGLE BRACKET

GLOBAL STANDARD COMPONENTS



Assembly

08/13/07

Tolerances:

- 1 PLACE MACHINING ± 0.3
- 1 PLACE FABRICATION ± 1.5
- 2 PLACE ± 0.08 BETWEEN MACHINED SURFACES
 - ± 0.03 BETWEEN SINGLE DOWEL AND A HEEL SURFACE
 - ± 0.03 BETWEEN DOWELS IN THE SAME PLANE
 - ± 0.10 BETWEEN DOWELS IN DIFFERENT PLANES
 - ± 0.13 TO SCREW HOLES, NON ACCUMULATIVE

MATERIAL: STEEL ASTM A-36
SEE PAGE B-1.1 FOR GLOBAL MATERIALS CHART

✓ SURFACES TO BE FLAT, PARALLEL & PERPENDICULAR TO WITHIN 0.015 T.I.R.
NOTES: ALL DIMENSIONS METRIC UNLESS OTHERWISE NOTED.

D
F

E

C

A

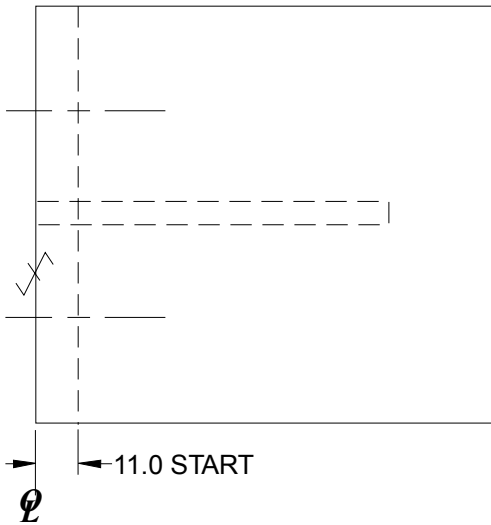

NAAMS CODE	"A" DIM	WT. kg
AHB001E	13/32	2.5
AHB002E	3/8-16 TAP	2.5

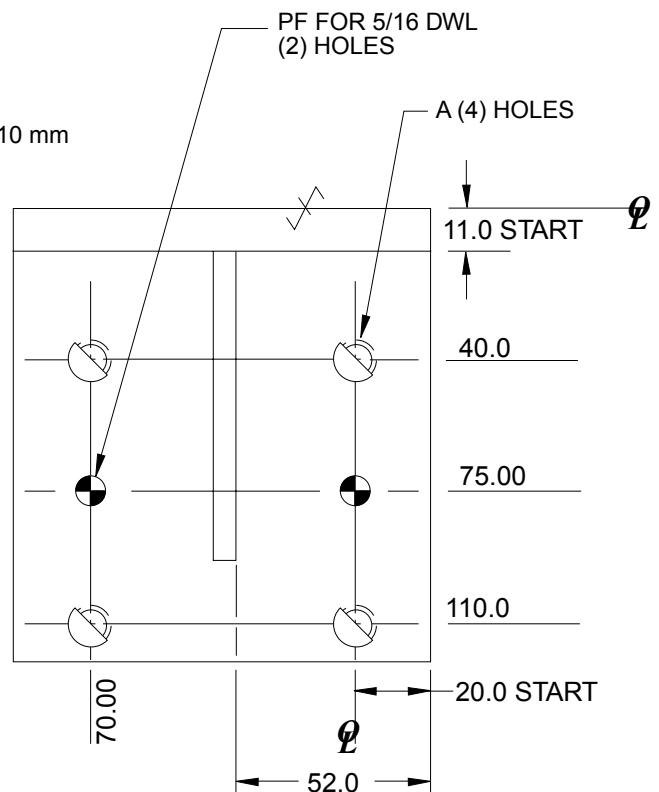
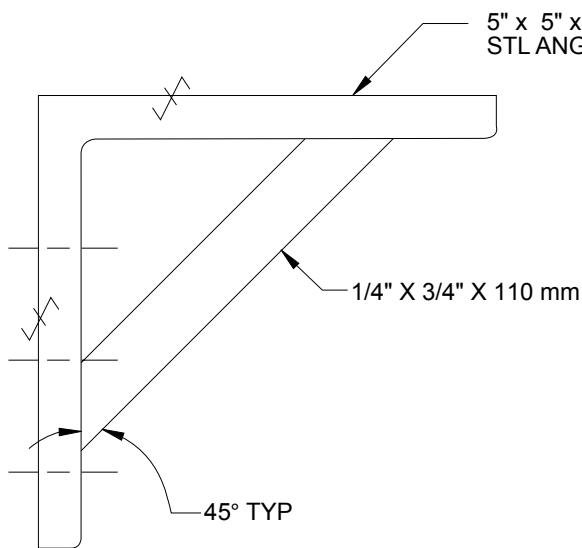

B

STACK RISER

GLOBAL STANDARD COMPONENTS



Assembly

12/02/19

Tolerances:

- 1 PLACE MACHINING ± 0.3
- 1 PLACE FABRICATION ± 1.5
- 2 PLACE ± 0.08 BETWEEN MACHINED SURFACES
- ± 0.03 BETWEEN SINGLE DOWEL AND A HEEL SURFACE
- ± 0.03 BETWEEN DOWELS IN THE SAME PLANE
- ± 0.10 BETWEEN DOWELS IN DIFFERENT PLANES
- ± 0.13 TO SCREW HOLES, NON ACCUMULATIVE

NOTES: ALL DIMENSIONS METRIC UNLESS OTHERWISE NOTED. IDENTIFY WITH NAAMS CODE NUMBER AS SHOWN **XXX**.

TYPICAL CONFIGURATION WILL VARY ACCORDING TO DESIGN AND METHOD OF FABRICATION

WHERE WELDED, FILLET WELD FULL LENGTH TO AWS D1.1 BOTH SIDES OF JOINT

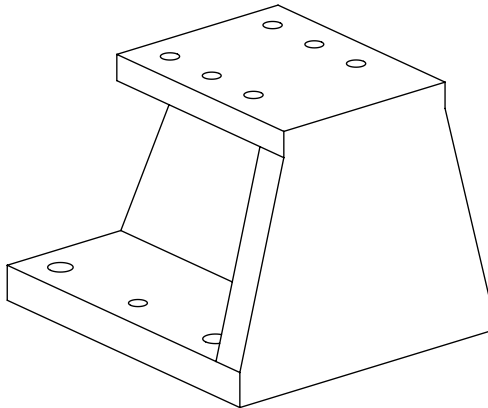

PART NO.	A
ASR115	150
ASR120	200
ASR125	250
ASR130	300
ASR135	350
ASR140	400
ASR145	450
ASR150	500

MATERIAL: STEEL ASTM A-36
SEE PAGE B-1.1 FOR GLOBAL MATERIALS CHART

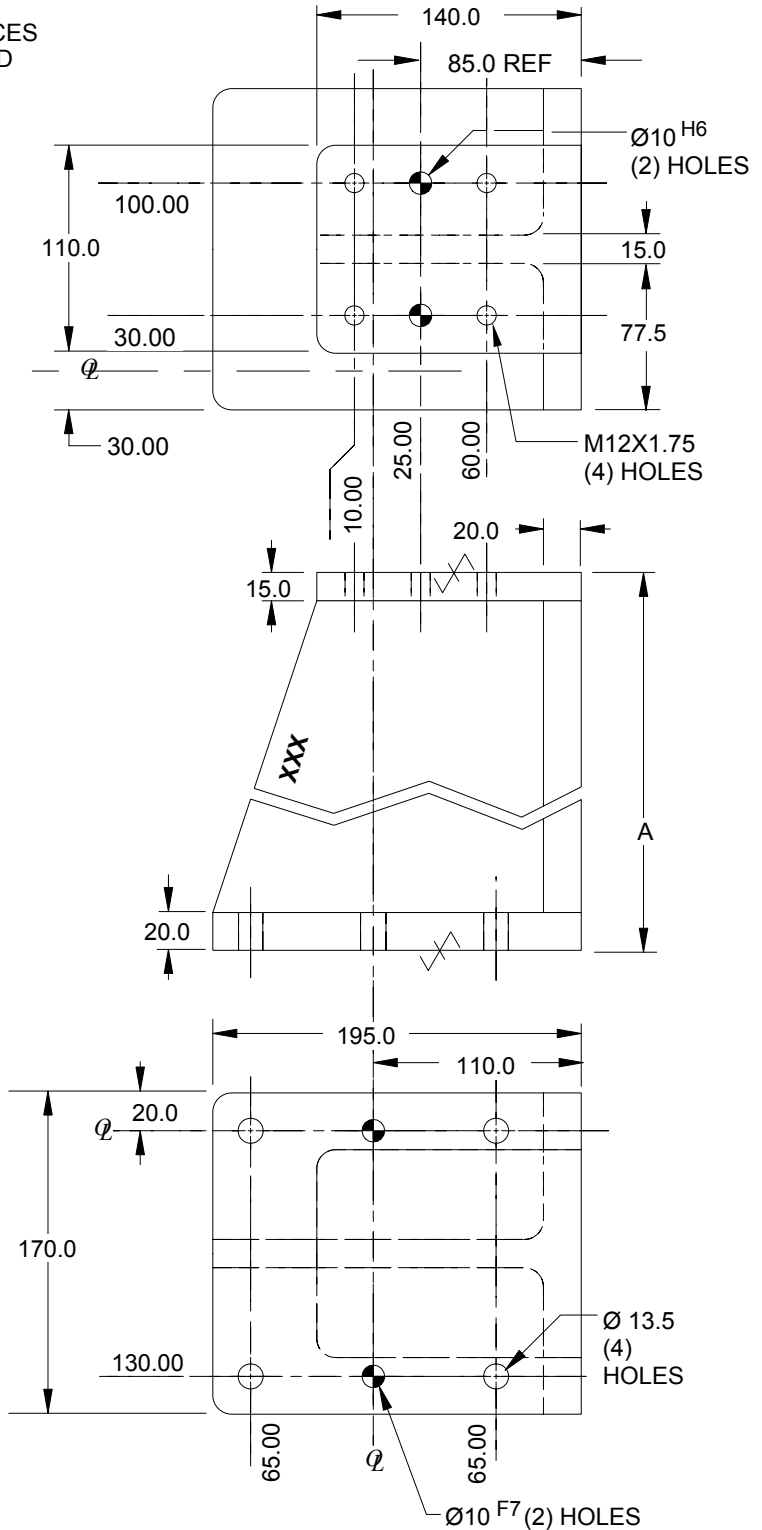

E

F

A

B

H

C

D

G

STACK RISER

GLOBAL STANDARD COMPONENTS



Assembly

12/02/19

Tolerances:

- 1 PLACE MACHINING ± 0.3
- 1 PLACE FABRICATION ± 1.5
- 2 PLACE ± 0.08 BETWEEN MACHINED SURFACES
- ± 0.03 BETWEEN SINGLEDOWEL AND A HEEL SURFACE
- ± 0.03 BETWEEN DOWELS IN THE SAME PLANE
- ± 0.10 BETWEEN DOWELS IN DIFFERENT PLANES
- ± 0.13 TO SCREW HOLES, NON ACCUMULATIVE

NOTES: ALL DIMENSIONS METRIC UNLESS OTHERWISE NOTED. IDENTIFY WITH NAAMS CODE NUMBER AS SHOWN **XXX**.

TYPICAL CONFIGURATION WILL VARY ACCORDING TO DESIGN AND METHOD OF FABRICATION

WHERE WELDED, FILLET WELD FULL LENGTH TO AWS D1.1 BOTH SIDES OF JOINT

MATERIAL: STEEL ASTM A-36
SEE PAGE B-1.1 FOR GLOBAL MATERIALS CHART

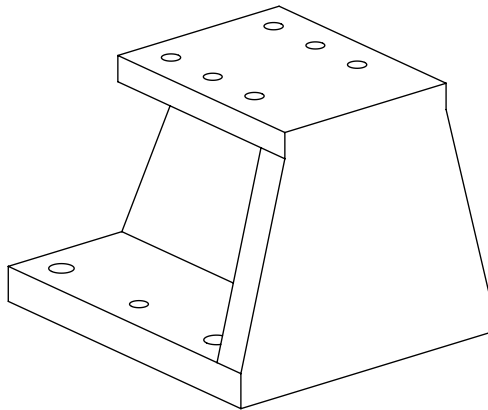

PART NO.	A
ASR 240	400
ASR 280	800

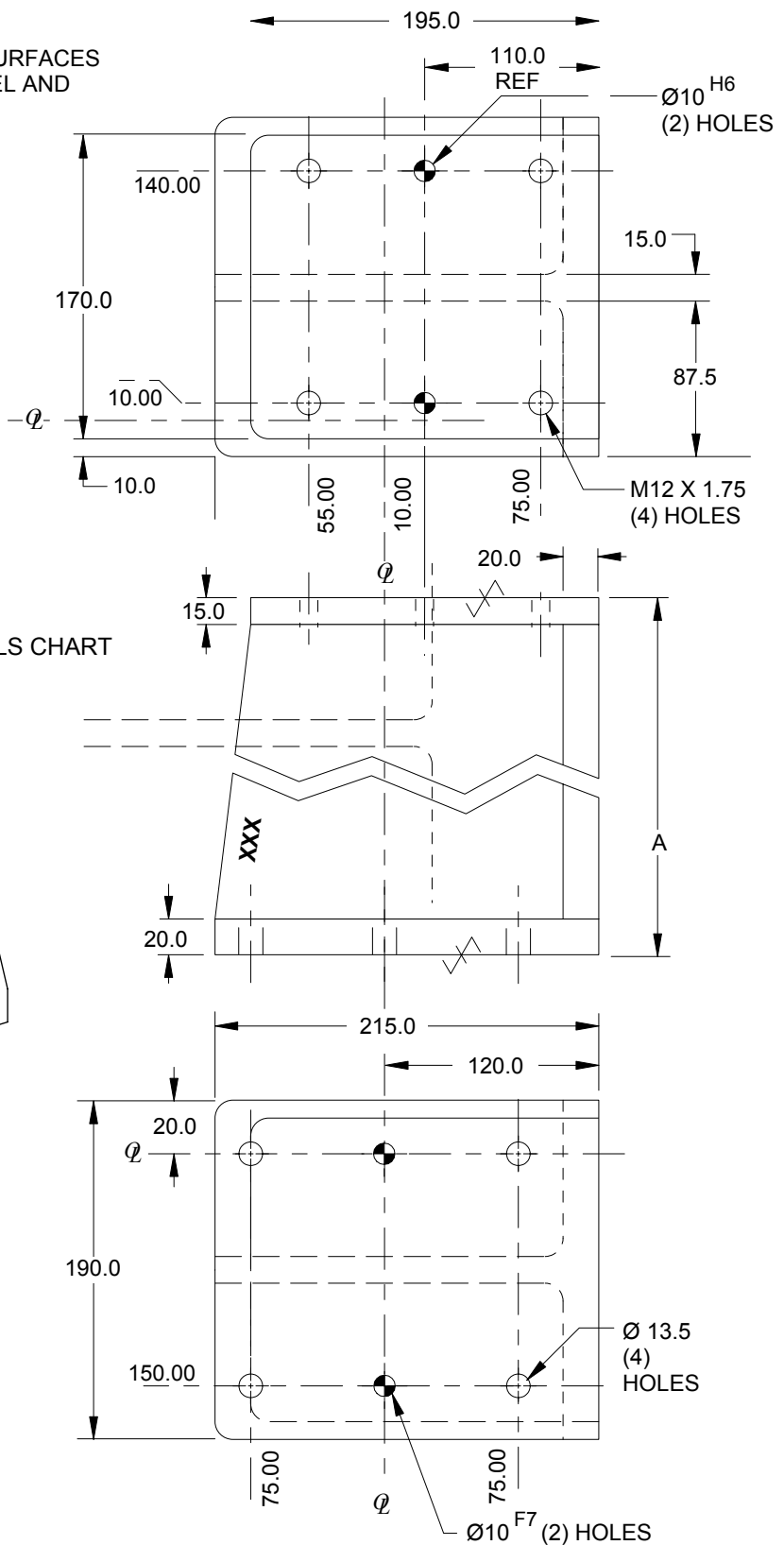

D
B
A
H
C
F
G

MAXIMUM RECOMMENDED LOADS

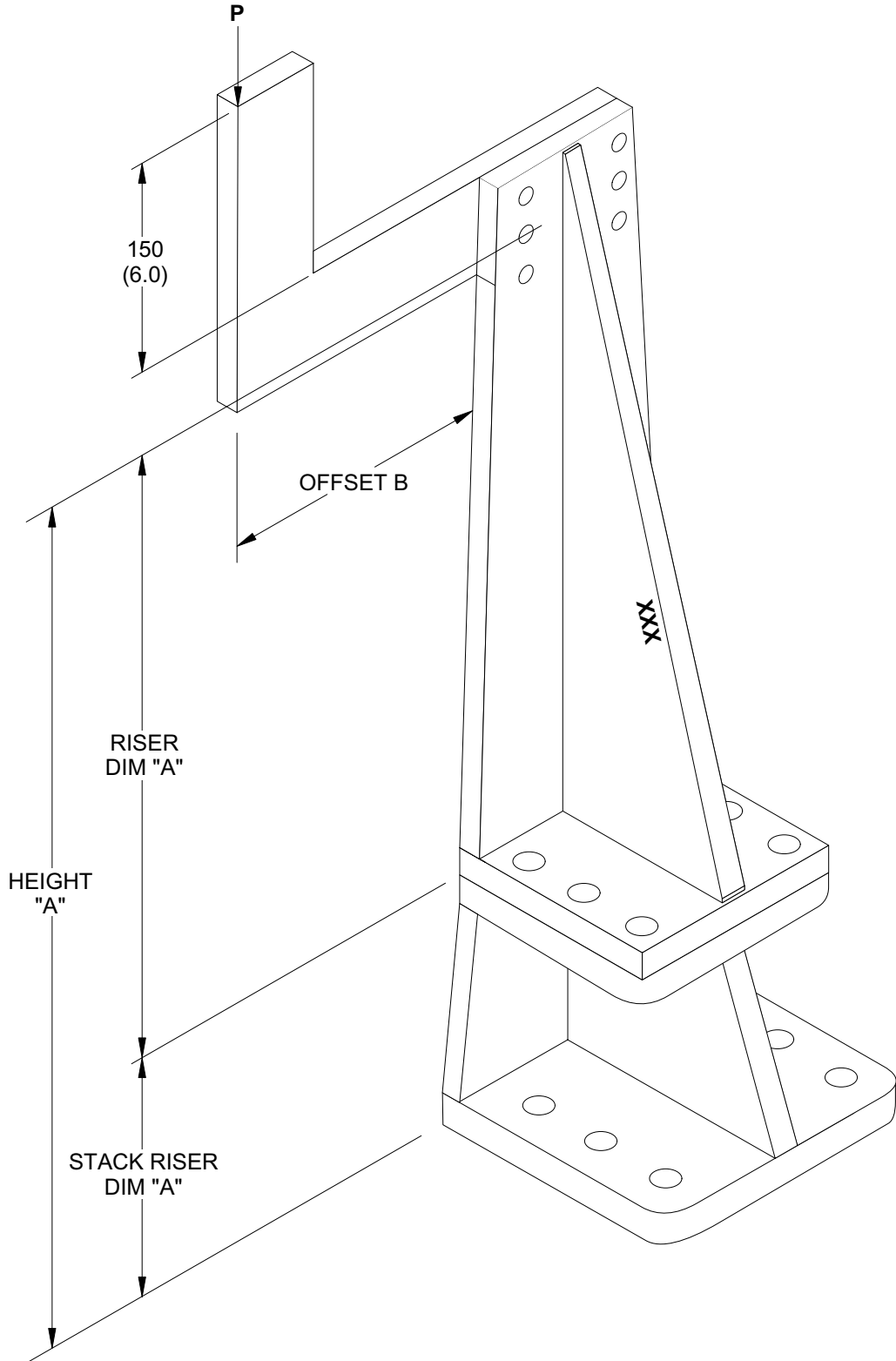

SEE TABLE OF RECOMMENDED LOADS ON FOLLOWING PAGE

MAXIMUM RECOMMENDED LOADS

MAXIMUM RECOMMENDED LOAD FOR 0.13 mm (0.005 IN) DEFLECTION
 OFFSET VALUES (B) AND POINTS OF APPLICATION OF LOAD P ARE DEFINED IN THE FIGURE ON PRECEDING PAGE.
 ALLOWABLE 0.13 mm (0.005 in) DEFLECTIONS ARE MEASURED AT THE POINT OF APPLICATION OF LOAD P, AND DO NOT
 INCLUDE DEFLECTIONS OF THE BLADE.
 MAXIMUM RECOMMENDED LOADS ARE BASED ON STEEL WITH A MODULUS OF ELASTICITY OF 207 GPa (30,000,000 PSI).
 CAST IRON ALLOYS MAY BE USED PROVIDED THEY HAVE A MODULUS OF ELASTICITY OF AT LEAST 165 GPa (24,000,000 PSI).

B
A

Riser Combination	Height A	Offset B	Load	
			N	lb
ASR115 & AAB151	300	300	844	190
		250	1,099	247
		200	1,475	332
		150	2,053	462
		100	2,962	666
ASR115 & AAB201	350	300	698	157
		250	904	203
		200	1,206	271
		150	1,662	374
		100	2,362	531
ASR115 & AAB251	400	300	591	133
		250	762	171
		200	1,010	227
		150	1,378	310
		100	1,927	434
ASR115 & AAB301	450	300	507	114
		250	651	147
		200	859	193
		150	1,164	262
		100	1,613	363
ASR115 & AAB351	500	300	436	98
		250	560	126
		200	738	166
		150	1,000	225
		100	1,384	312
ASR115 & AAB401	550	300	378	85
		250	484	109
		200	635	143
		150	853	192
		100	1,169	263
ASR120 & AAB151	350	300	773	174
		250	1,001	225
		200	1,334	300
		150	1,836	413
		100	2,601	585
ASR120 & AAB201	400	300	649	146
		250	838	189
		200	1,113	250
		150	1,524	343
		100	2,145	483
ASR120 & AAB251	450	300	551	124
		250	708	159
		200	934	210
		150	1,267	285
		100	1,755	395
ASR120 & AAB301	500	300	476	107
		250	611	137
		200	805	181
		150	1,089	245
		100	1,505	339

Riser Combination	Height A	Offset B	Load	
			N	lb
ASR120 & AAB351	550	300	409	92
		250	525	118
		200	691	155
		150	933	210
		100	1,287	290
ASR120 & AAB401	600	300	356	80
		250	456	103
		200	600	135
		150	809	182
		100	1,113	250
ASR125 & AAB151	400	300	711	160
		250	920	207
		200	1,227	276
		150	1,689	380
		100	2,394	539
ASR125 & AAB201	450	300	600	135
		250	773	174
		200	1,024	230
		150	1,396	314
		100	1,949	439
ASR125 & AAB251	500	300	516	116
		250	661	149
		200	870	196
		150	1,173	264
		100	1,615	363
ASR125 & AAB301	550	300	444	100
		250	570	128
		200	750	169
		150	1,013	228
		100	1,396	314
ASR125 & AAB351	600	300	382	86
		250	491	110
		200	647	146
		150	876	197
		100	1,210	272
ASR125 & AAB401	650	300	338	76
		250	432	97
		200	566	127
		150	760	171
		100	1,038	234
ASR130 & AAB151	450	300	658	148
		250	849	191
		200	1,127	254
		150	1,542	347
		100	2,166	487
ASR130 & AAB201	500	300	560	126
		250	720	162
		200	952	214
		150	1,293	291
		100	1,798	405

SEE DRAWING ON PRECEDING PAGE

TABLE OF RECOMMENDED LOADS CONTINUED ON FOLLOWING PAGE

MAXIMUM RECOMMENDED LOADS

MAXIMUM RECOMMENDED LOAD FOR 0.13 mm (0.005 IN) DEFLECTION

OFFSET VALUES (B) AND POINTS OF APPLICATION OF LOAD P ARE DEFINED IN THE FIGURE ON PAGE E-12.

ALLOWABLE 0.13 mm (0.005 in) DEFLECTIONS ARE MEASURED AT THE POINT OF APPLICATION OF LOAD P, AND DO NOT INCLUDE DEFLECTIONS OF THE BLADE.

MAXIMUM RECOMMENDED LOADS ARE BASED ON STEEL WITH A MODULUS OF ELASTICITY OF 207 GPa (30,000,000 PSI). CAST IRON ALLOYS MAY BE USED PROVIDED THEY HAVE A MODULUS OF ELASTICITY OF AT LEAST 165 GPa (24,000,000 PSI).

B
A

Riser Combination	Height A	Offset B	Load	
			N	lb
ASR130 & AAB251	550	300	480	108
		250	616	139
		200	810	182
		150	1,093	246
		100	1,506	339
ASR130 & AAB301	600	300	413	93
		250	531	119
		200	700	157
		150	947	213
		100	1,308	294
ASR130 & AAB351	650	300	360	81
		250	461	104
		200	607	136
		150	818	184
		100	1,124	253
ASR130 & AAB401	700	300	316	71
		250	404	91
		200	531	120
		150	716	161
		100	982	221
ASR135 & AAB151	500	300	609	137
		250	783	176
		200	1,034	233
		150	1,404	316
		100	1,951	439
ASR135 & AAB201	550	300	516	116
		250	663	149
		200	877	197
		150	1,191	268
		100	1,656	373
ASR135 & AAB251	600	300	449	101
		250	575	129
		200	756	170
		150	1,018	229
		100	1,397	314
ASR135 & AAB301	650	300	391	88
		250	500	113
		200	656	148
		150	880	198
		100	1,202	270
ASR135 & AAB351	700	300	342	77
		250	438	98
		200	573	129
		150	769	173
		100	1,049	236
ASR135 & AAB401	750	300	298	67
		250	382	86
		200	501	113
		150	676	152
		100	928	209

Riser Combination	Height A	Offset B	Load	
			N	lb
ASR140 & AAB151	550	300	560	126
		250	720	162
		200	952	214
		150	1,293	291
		100	1,798	405
ASR140 & AAB201	600	300	480	108
		250	617	139
		200	815	183
		150	1,107	249
		100	1,537	346
ASR140 & AAB251	650	300	418	94
		250	535	120
		200	701	158
		150	942	212
		100	1,289	290
ASR140 & AAB301	700	300	364	82
		250	466	105
		200	612	138
		150	822	185
		100	1,125	253
ASR140 & AAB351	750	300	316	71
		250	405	91
		200	533	120
		150	720	162
		100	993	223
ASR140 & AAB401	800	300	280	63
		250	359	81
		200	472	106
		150	636	143
		100	873	196
ASR145 & AAB151	600	300	520	117
		250	667	150
		200	878	198
		150	1,187	267
		100	1,636	368
ASR145 & AAB201	650	300	449	101
		250	577	130
		200	763	172
		150	1,036	233
		100	1,438	324
ASR145 & AAB251	700	300	387	87
		250	496	112
		200	652	147
		150	880	198
		100	1,211	273
ASR145 & AAB301	750	300	342	77
		250	438	98
		200	573	129
		150	769	173
		100	1,049	236

TABLE OF RECOMMENDED LOADS CONTINUED ON FOLLOWING PAGE

MAXIMUM RECOMMENDED LOADS

MAXIMUM RECOMMENDED LOAD FOR 0.13 mm (0.005 IN) DEFLECTION
 OFFSET VALUES (B) AND POINTS OF APPLICATION OF LOAD P ARE DEFINED IN THE FIGURE ON PAGE E-12.
 ALLOWABLE 0.13 mm (0.005 in) DEFLECTIONS ARE MEASURED AT THE POINT OF APPLICATION OF LOAD P, AND DO NOT
 INCLUDE DEFLECTIONS OF THE BLADE.
 MAXIMUM RECOMMENDED LOADS ARE BASED ON STEEL WITH A MODULUS OF ELASTICITY OF 207 GPa (30,000,000 PSI).
 CAST IRON ALLOYS MAY BE USED PROVIDED THEY HAVE A MODULUS OF ELASTICITY OF AT LEAST 165 GPa (24,000,000 PSI).

B
A

Riser Combination	Height A	Offset B	Load	
			N	lb
ASR145 & AAB351	800	300	298	67
		250	382	86
		200	501	113
		150	676	152
		100	928	209
ASR145 & AAB401	850	300	267	60
		250	341	77
		200	447	101
		150	600	135
		100	820	184
ASR150 & AAB151	650	300	480	108
		250	616	139
		200	812	183
		150	1,098	247
		100	1,516	341
ASR150 & AAB201	700	300	418	94
		250	535	120
		200	701	158
		150	942	212
		100	1,289	290
ASR150 & AAB251	750	300	364	82
		250	466	105
		200	612	138
		150	822	185
		100	1,125	253
ASR150 & AAB301	800	300	316	71
		250	405	91
		200	533	120
		150	720	162
		100	993	223
ASR150 & AAB351	850	300	284	64
		250	363	82
		200	475	107
		150	636	143
		100	864	194
ASR150 & AAB401	900	300	249	56
		250	319	72
		200	419	94
		150	564	127
		100	775	174
ASR240 & ARA451	850	300	564	127
		250	718	161
		200	932	210
		150	1,236	278
		100	1,658	373
ASR240 & ARA501	900	300	520	117
		250	660	149
		200	857	193
		150	1,133	255
		100	1,517	341

Riser Combination	Height A	Offset B	Load	
			N	lb
ASR240 & ARA551	950	300	476	107
		250	604	136
		200	783	176
		150	1,036	233
		100	1,385	312
ASR240 & ARA601	1000	300	440	99
		250	558	125
		200	722	162
		150	951	214
		100	1,266	285
ASR240 & ARA651	1050	300	404	91
		250	513	115
		200	664	149
		150	876	197
		100	1,167	263
ASR240 & ARA701	1100	300	373	84
		250	473	107
		200	613	138
		150	809	182
		100	1,079	243
ASR240 & ARA751	1150	300	347	78
		250	439	99
		200	567	128
		150	747	168
		100	992	223
ASR240 & ARA801	1200	300	320	72
		250	406	91
		200	525	118
		150	693	156
		100	924	208
ASR280 & ARA451	1250	300	387	87
		250	488	110
		200	627	141
		150	818	184
		100	1,074	242
ASR280 & ARA501	1300	300	360	81
		250	454	102
		200	585	132
		150	764	172
		100	1,007	227
ASR280 & ARA551	1350	300	333	75
		250	421	95
		200	543	122
		150	711	160
		100	939	211
ASR280 & ARA601	1400	300	311	70
		250	392	88
		200	504	113
		150	658	148
		100	864	194

TABLE OF RECOMMENDED LOADS CONTINUED ON FOLLOWING PAGE

MAXIMUM RECOMMENDED LOADS

MAXIMUM RECOMMENDED LOAD FOR 0.13 mm (0.005 IN) DEFLECTION
 OFFSET VALUES (B) AND POINTS OF APPLICATION OF LOAD P ARE DEFINED IN THE FIGURE ON PAGE E-12.
 ALLOWABLE 0.13 mm (0.005 in) DEFLECTIONS ARE MEASURED AT THE POINT OF APPLICATION OF LOAD P, AND DO NOT
 INCLUDE DEFLECTIONS OF THE BLADE.
 MAXIMUM RECOMMENDED LOADS ARE BASED ON STEEL WITH A MODULUS OF ELASTICITY OF 207 GPa (30,000,000 PSI).
 CAST IRON ALLOYS MAY BE USED PROVIDED THEY HAVE A MODULUS OF ELASTICITY OF AT LEAST 165 GPa (24,000,000 PSI).

B
A

Riser Combination	Height A	Offset B	Load	
			N	lb
ASR280 & ARA651	1450	300	289	65
		250	364	82
		200	467	105
		150	609	137
		100	798	180
ASR280 & ARA701	1500	300	271	61
		250	342	77
		200	439	99
		150	573	129
		100	753	169
ASR280 & ARA751	1550	300	249	56
		250	314	71
		200	404	91
		150	529	119
		100	697	157
ASR280 & ARA801	1600	300	231	52
		250	293	66
		200	380	86
		150	502	113
		100	671	151

TABLE OF RECOMMENDED LOADS CONTINUED FROM PREVIOUS PAGE

TUBULAR RISER CONSTRUCTION

1 PLACE FABRICATION
 TOLERANCES ± 1.5

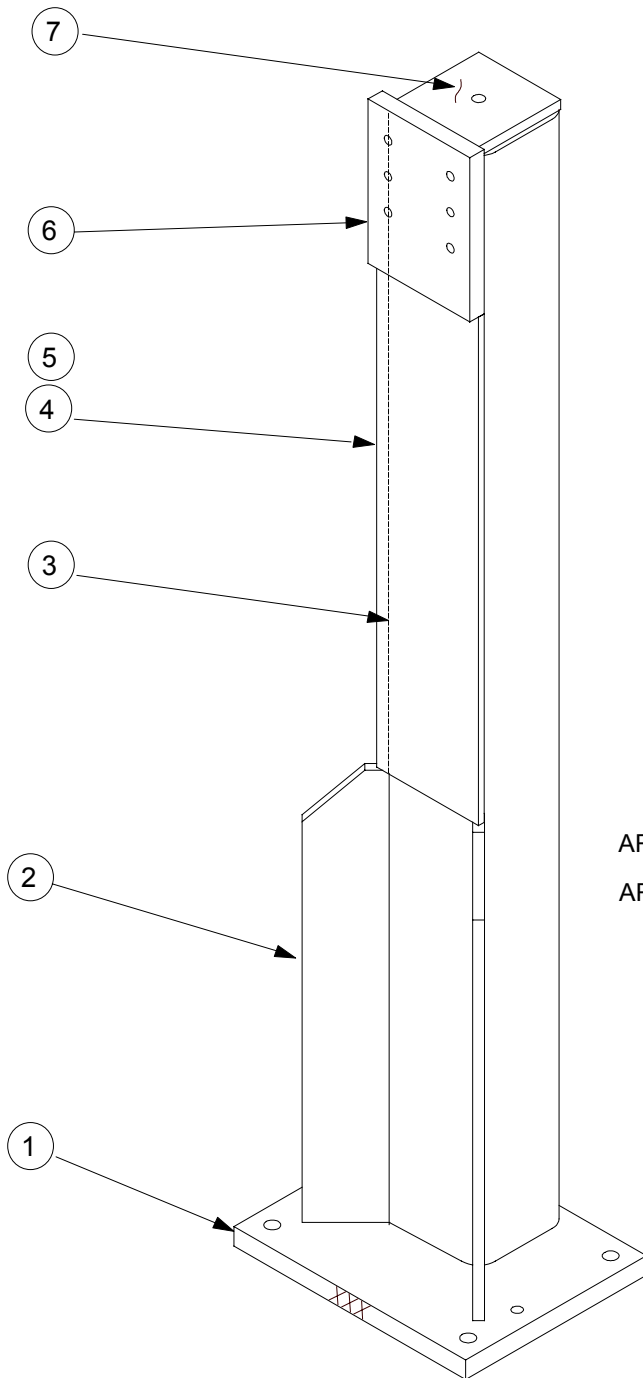

NAMMS CODE	"B"	"C"
ARB085M AND ARB085E	880.0	440.0
ARB090M AND ARB090E	930.0	465.0
ARB095M AND ARB095E	980.0	490.0
ARB100M AND ARB100E	1030.0	515.0
ARB105M AND ARB105E	1080.0	540.0
ARB110M AND ARB110E	1130.0	565.0
ARB115M AND ARB115E	1180.0	590.0
ARB120M AND ARB120E	1230.0	615.0
ARB125M AND ARB125E	1280.0	640.0
ARB130M AND ARB130E	1330.0	665.0
ARB135M AND ARB135E	1380.0	690.0
ARB140M AND ARB140E	1430.0	715.0
ARB145M AND ARB145E	1480.0	740.0
ARB150M AND ARB150E	1530.0	765.0
ARB155M AND ARB155E	1580.0	790.0
ARB160M AND ARB160E	1630.0	815.0

RISER BRACKET
 WELDED CONST. ~ STRESS RELIEVE

- ① 1-STEEL ASTM A-36 ~ 7/8" x 8" x 260.0mm LG.
- ② 2-STEEL ASTM A-36 ~ 3/8" x 3" x "C" LG.
- ③ 1-STEEL TUBING ~ 4" x 4" x 3/8 W/T x "B" LG.
 ASTM A500 GRADE B
- ARB155 ④ 1-STEEL ASTM A-36 ~ 1/4" x 4 1/2" x 645.0mm LG.
- ARB160 ⑤ 1-STEEL ASTM A-36 ~ 1/4" x 4 1/2" x 670.0mm LG.
- ⑥ 1-STEEL ASTM A-36 ~ 3/4" x 4 1/2" x 160.0mm LG.
- ⑦ 1-STEEL ASTM A-36 ~ 3/8" x 3 5/8" x 97.0mm LG.

MATERIAL: STEEL ASTM A-36
 SEE PAGE B-1.1 FOR GLOBAL MATERIALS CHART

NOTES: ALL DIMENSIONS ARE METRIC
 UNLESS OTHERWISE NOTED
 IDENTIFY WITH NAAMS CODE
 NUMBER AS SHOWN XXX

A

B

TUBULAR RISER

ARB085M THRU ARB160M

GLOBAL STANDARD COMPONENTS



Assembly

07/15/03

Tolerances:

- 1 PLACE MACHINING ± 0.3
- 1 PLACE FABRICATION ± 1.5
- 2 PLACE ± 0.08 BETWEEN MACHINED SURFACES
- ± 0.03 BETWEEN SINGLE DOWEL AND A HEEL SURFACE
- ± 0.03 BETWEEN DOWELS IN THE SAME PLANE
- ± 0.10 BETWEEN DOWELS IN DIFFERENT PLANES
- ± 0.13 TO SCREW HOLES, NON ACCUMULATIVE

NOTES: ALL DIMENSIONS METRIC UNLESS OTHERWISE NOTED.
IDENTIFY WITH NAAMS CODE NUMBER AS SHOWN XXX.

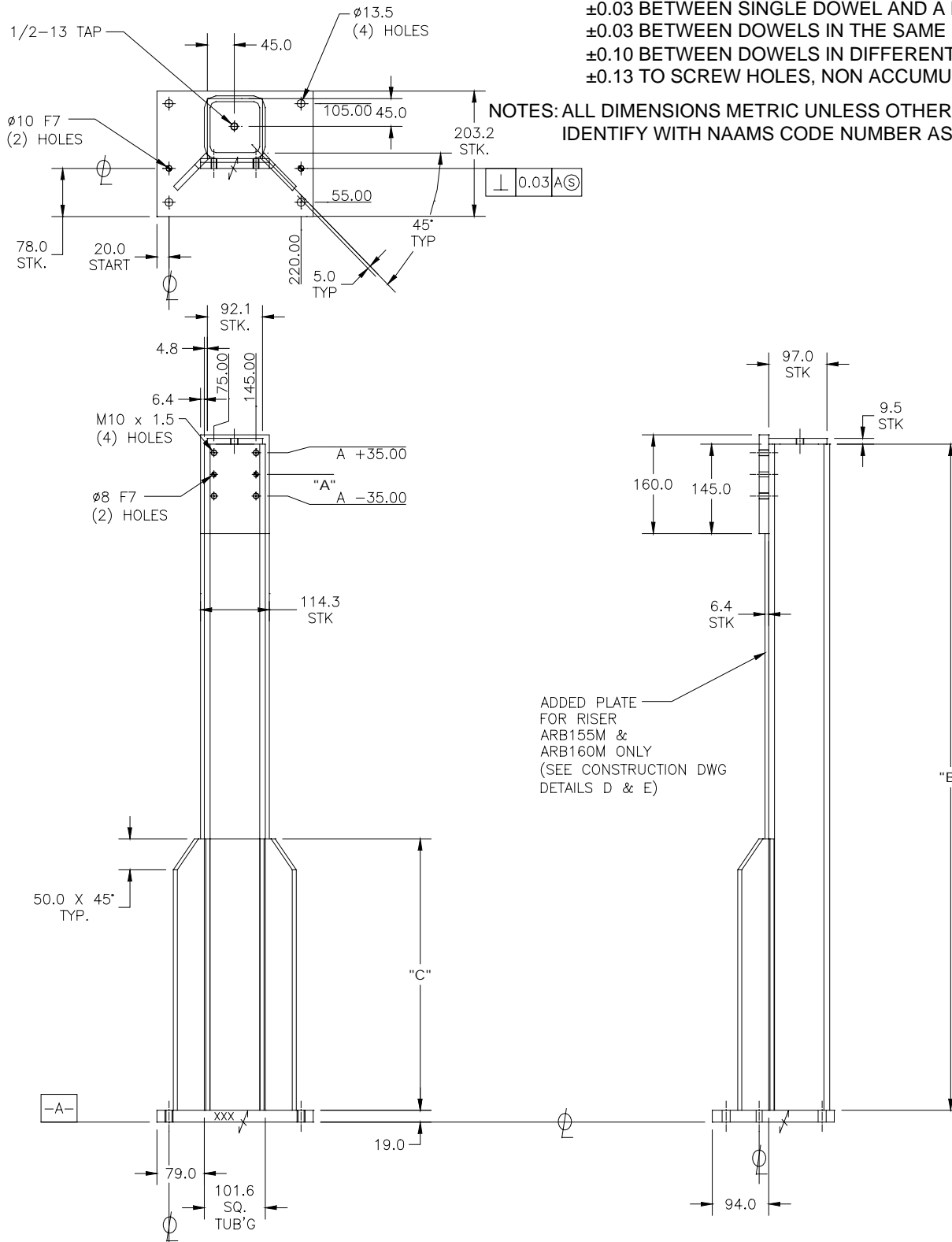

TUBULAR RISER

ARB085E THRU ARB160E

Tolerances:

- 1 PLACE MACHINING ± 0.3
- 1 PLACE FABRICATION ± 1.5
- 2 PLACE ± 0.08 BETWEEN MACHINED SURFACES
- ± 0.03 BETWEEN SINGLE DOWEL AND A HEEL SURFACE
- ± 0.03 BETWEEN DOWELS IN THE SAME PLANE
- ± 0.10 BETWEEN DOWELS IN DIFFERENT PLANES
- ± 0.13 TO SCREW HOLES, NON ACCUMULATIVE

**NOTES: ALL DIMENSIONS METRIC UNLESS OTHERWISE NOTED.
 IDENTIFY WITH NAAMS CODE NUMBER AS SHOWN XXX.**

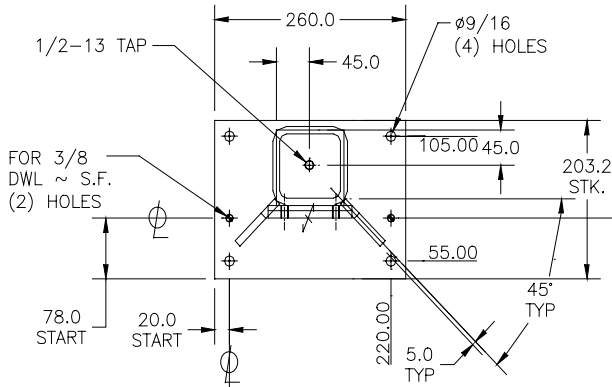

\perp 0.03 A(S)

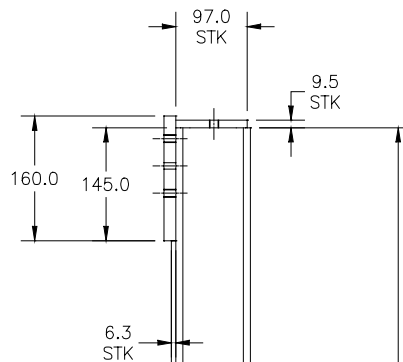
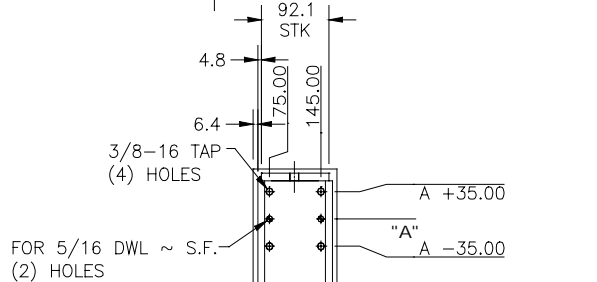

ADDED PLATE FOR RISER ARB155E & ARB160E ONLY (SEE CONSTRUCTION DWG DETAILS D & E)

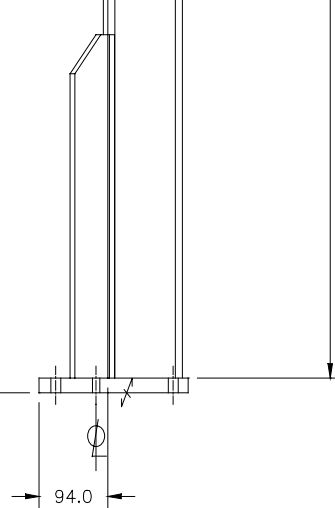
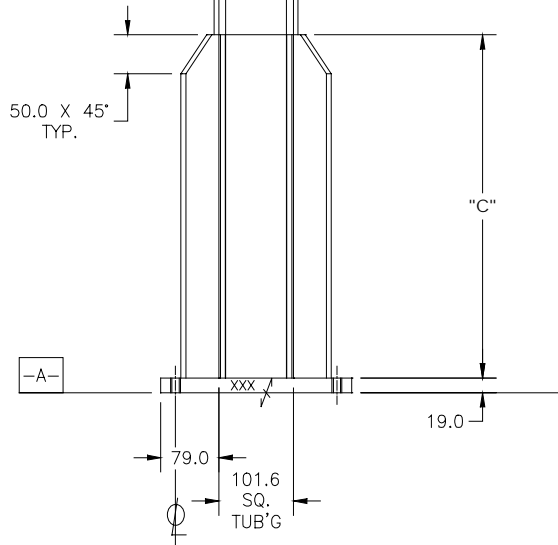

TUBULAR RISER ARB085M THRU ARB160M & ARB085E THRU ARB160E

NAMMS CODE	"A" DIM	"B"	"C"	WT. kg
ARB085M AND ARB085E	850.00	880.0	440.0	43.1
ARB090M AND ARB090E	900.00	930.0	465.0	44.9
ARB095M AND ARB095E	950.00	980.0	490.0	46.7
ARB100M AND ARB100E	1000.00	1030.0	515.0	48.5
ARB105M AND ARB105E	1050.00	1080.0	540.0	50.3
ARB110M AND ARB110E	1100.00	1130.0	565.0	52.2
ARB115M AND ARB115E	1150.00	1180.0	590.0	54.0
ARB120M AND ARB120E	1200.00	1230.0	615.0	55.8
ARB125M AND ARB125E	1250.00	1280.0	640.0	57.6
ARB130M AND ARB130E	1300.00	1330.0	665.0	59.4
ARB135M AND ARB135E	1350.00	1380.0	690.0	61.2
ARB140M AND ARB140E	1400.00	1430.0	715.0	63.0
ARB145M AND ARB145E	1450.00	1480.0	740.0	64.9
ARB150M AND ARB150E	1500.00	1530.0	765.0	66.7
ARB155M AND ARB155E	1550.00	1580.0	790.0	72.6
ARB160M AND ARB160E	1600.00	1630.0	815.0	74.4

A

TUBULAR RISER MAXIMUM RECOMMENDED LOADS

GLOBAL STANDARD COMPONENTS



Assembly

07/15/03

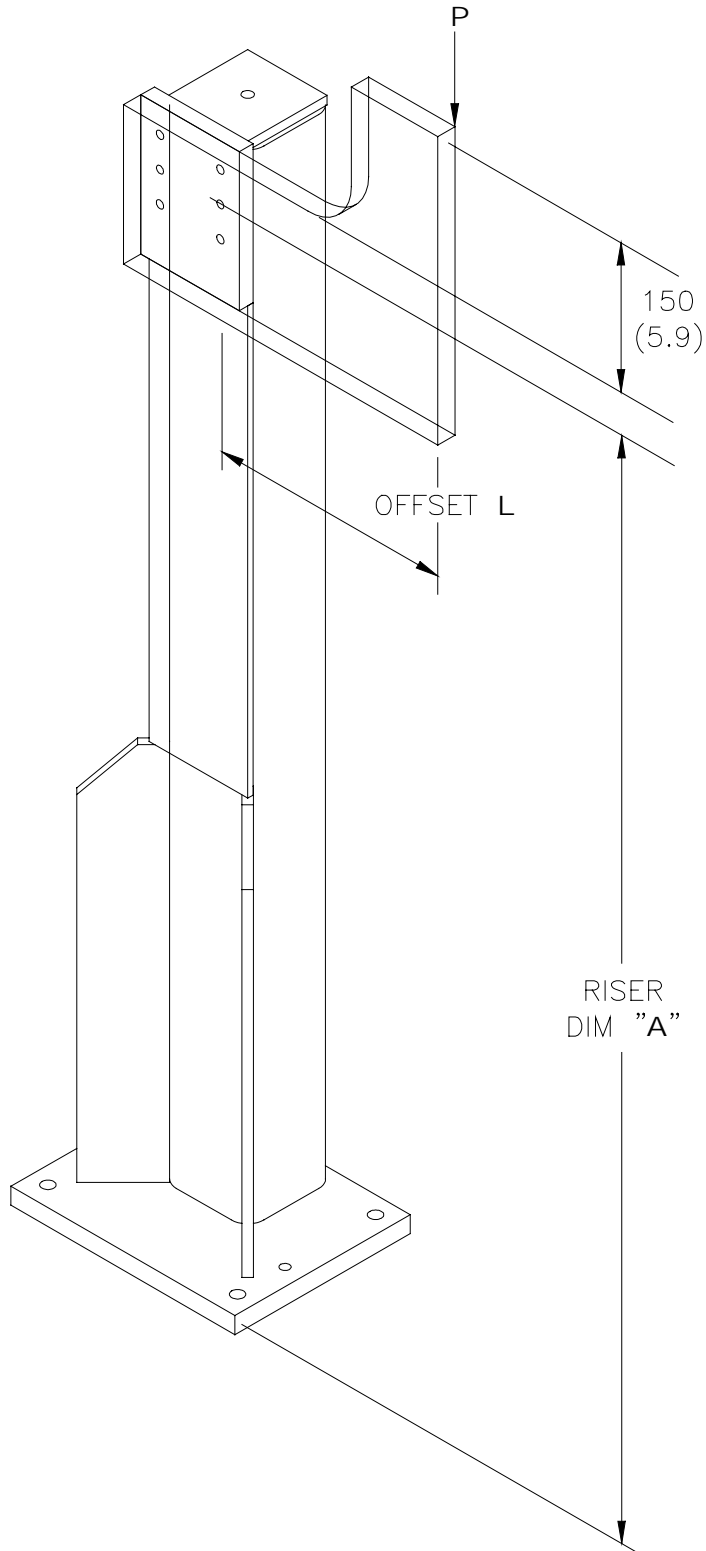

TUBULAR RISER MAXIMUM RECOMMENDED LOADS

GLOBAL STANDARD COMPONENTS



Assembly

10/06/03

NAAMS CODE	OFFSET L		LOAD P	
	mm	In.	N	lb
ARB085M and ARB085E	300	12	853	192
	250	10	1032	232
	200	8	1288	290
	150	6	1621	365
	100	4	2184	492
ARB090M and ARB090E	300	12	835	188
	250	10	993	223
	200	8	1218	274
	150	6	1510	340
	100	4	2005	451
ARB095M and ARB095E	300	12	786	177
	250	10	930	209
	200	8	1136	256
	150	6	1404	316
	100	4	1857	418
ARB100M and ARB100E	300	12	711	160
	250	10	851	191
	200	8	1050	236
	150	6	1310	295
	100	4	1749	394
ARB105M and ARB105E	300	12	702	158
	250	10	823	185
	200	8	997	224
	150	6	1222	275
	100	4	1603	361
ARB110M and ARB110E	300	12	666	150
	250	10	778	175
	200	8	938	211
	150	6	1146	258
	100	4	1498	337
ARB115M and ARB115E	300	12	631	142
	250	10	736	165
	200	8	885	199
	150	6	1079	243
	100	4	1408	317
ARB120M and ARB120E	300	12	600	135
	250	10	696	157
	200	8	834	188
	150	6	1013	228
	100	4	1316	296

NAAMS CODE	OFFSET L		LOAD P	
	mm	In.	N	lb
ARB125M and ARB125E	300	12	564	127
	250	10	655	147
	200	8	786	177
	150	6	955	215
	100	4	1242	279
ARB130M and ARB130E	300	12	542	122
	250	10	626	141
	200	8	746	168
	150	6	902	203
	100	4	1166	262
ARB135M and ARB135E	300	12	515	116
	250	10	595	134
	200	8	667	150
	150	6	852	192
	100	4	1100	248
ARB140M and ARB140E	300	12	493	111
	250	10	565	127
	200	8	667	150
	150	6	800	180
	100	4	1025	231
ARB145M and ARB145E	300	12	471	106
	250	10	539	121
	200	8	637	143
	150	6	764	172
	100	4	979	220
ARB150M and ARB150E	300	12	453	102
	250	10	517	116
	200	8	609	137
	150	6	729	164
	100	4	931	210
ARB155M and ARB155E	300	12	475	107
	250	10	540	122
	200	8	634	143
	150	6	755	170
	100	4	960	216
ARB160M and ARB160E	300	12	458	103
	250	10	521	117
	200	8	612	138
	150	6	729	164
	100	4	928	209

A

RISER ANGLE BRACKET-ALUMINUM

GLOBAL STANDARD COMPONENTS



Assembly

12/02/19

Tolerances:

- 1 PLACE MACHINING ± 0.3
- 1 PLACE FABRICATION ± 1.5
- 2 PLACE ± 0.08 BETWEEN MACHINED SURFACES
- ± 0.03 BETWEEN SINGLE DOWEL AND A HEEL SURFACE
- ± 0.03 BETWEEN DOWELS IN THE SAME PLANE
- ± 0.10 BETWEEN DOWELS IN DIFFERENT PLANES
- ± 0.13 TO SCREW HOLES, NON ACCUMULATIVE

NOTES: ALL DIMENSIONS METRIC UNLESS OTHERWISE NOTED.
IDENTIFY WITH NAAMS CODE NUMBER AS SHOWN **XXX**.

MATERIAL:

ASTM 713 CAST ALUMINUM

SEE PAGE B-1.1 FOR GLOBAL MATERIALS CHART

A

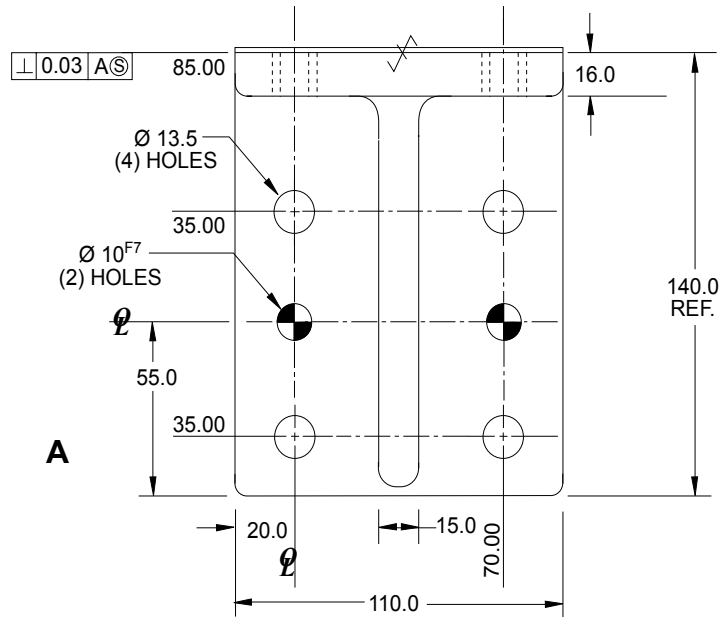
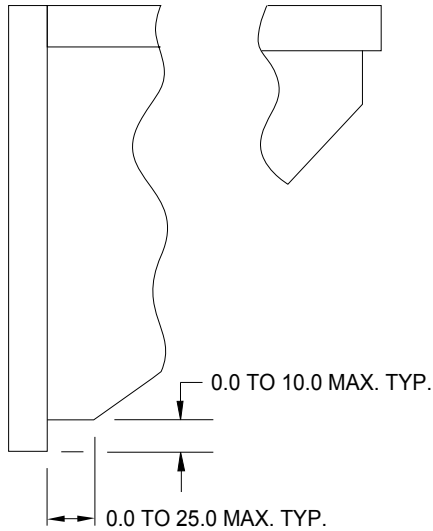

B

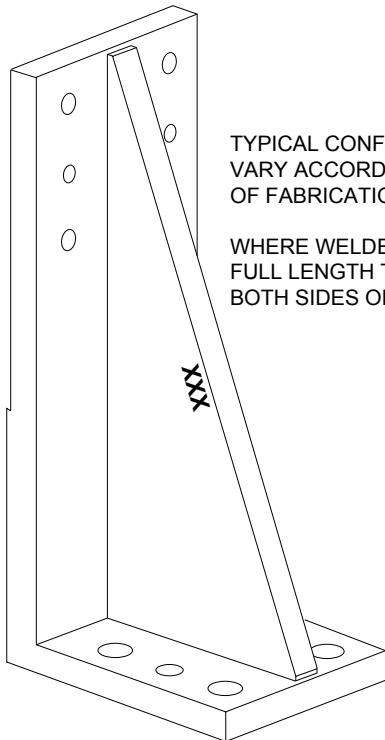

TYPICAL CONFIGURATION. WILL VARY ACCORDING TO METHOD OF FABRICATION

WHERE WELDED, FILLET WELD FULL LENGTH TO AWS D1.1 BOTH SIDES OF JOINT

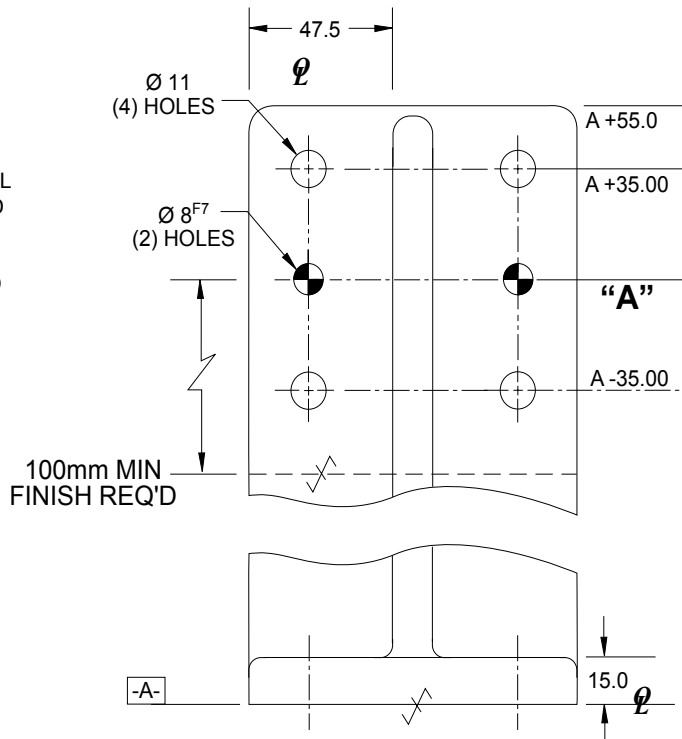

TABULATED INFORMATION ON FOLLOWING PAGE

RISER ANGLE BRACKET-ALUMINUM

NAAMS CODE	"A" DIM	WEIGHT	
		kg	lb
AAB101A	100.00	1.82	4.00
AAB151A	150.00	2.25	4.96
AAB201A	200.00	2.72	6.01
AAB251A	250.00	3.11	6.85
AAB301A	300.00	3.54	7.80
AAB351A	350.00	3.96	8.74
AAB401A	400.00	4.36	9.61

SEE DRAWING ON PRECEDING PAGE

NOTE: IT IS RECOMMENDED TO USE HARDENED FLAT WASHERS
ON FASTENERS ON ALUMINUM RISERS.

A

MAXIMUM RECOMMENDED LOADS

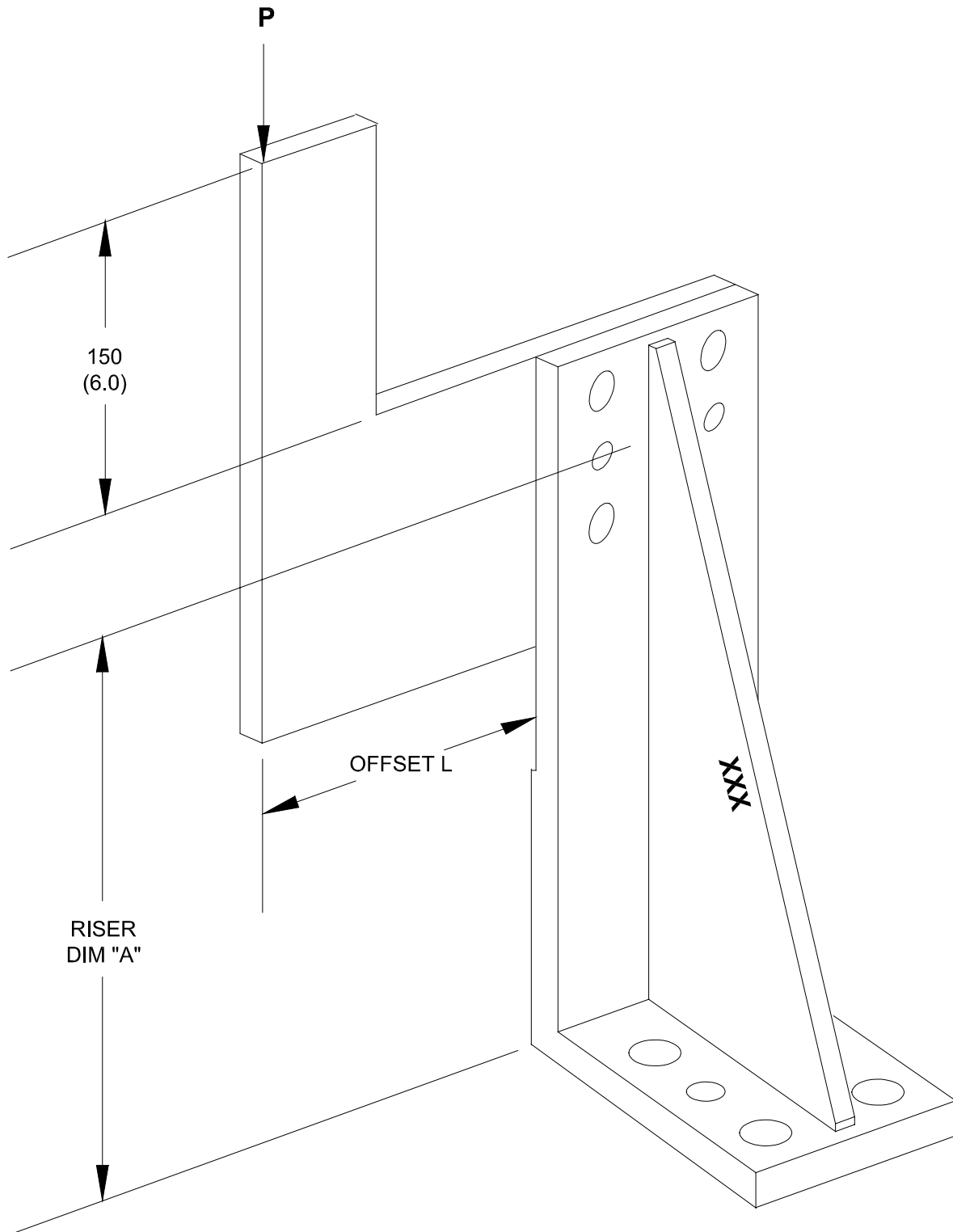

SEE TABLE OF RECOMMENDED LOADS ON FOLLOWING PAGE

MAXIMUM RECOMMENDED LOADS

MAXIMUM RECOMMENDED LOAD FOR 0.13 mm (0.005 in.) DEFLECTION

OFFSET VALUES (L) AND POINTS OF APPLICATION OF LOAD P ARE DEFINED IN THE FIGURE ON THE PRECEDING PAGE.

ALLOWABLE 0.13 mm (0.005 in.) DEFLECTIONS ARE MEASURED AT THE POINT OF APPLICATION OF LOAD P, AND DO NOT INCLUDE DEFLECTIONS OF THE BLADE.

MAXIMUM RECOMMENDED LOADS ARE BASED ON ALUMINUM WITH A MODULUS OF ELASTICITY OF 73 GPa (10,600,000 psi).

Riser	Offset L		Load P	
	mm	in.	N	lb
AAB101A	300	12	640	144
	250	10	835	188
	200	8	1,135	255
	150	6	1,667	375
	100	4	2,714	611
AAB151A	300	12	542	122
	250	10	703	158
	200	8	955	215
	150	6	1,387	312
	100	4	2,248	506
AAB201A	300	12	476	107
	250	10	614	138
	200	8	827	186
	150	6	1,204	271
	100	4	1,948	438
AAB251A	300	12	427	96
	250	10	549	124
	200	8	737	166
	150	6	1,071	241
	100	4	1,728	389
AAB301A	300	12	387	87
	250	10	497	112
	200	8	665	150
	150	6	964	217
	100	4	1,554	350
AAB351A	300	12	356	80
	250	10	455	102
	200	8	604	136
	150	6	880	198
	100	4	1,415	318
AAB401A	300	12	329	74
	250	10	417	94
	200	8	552	124
	150	6	791	178
	100	4	1,263	284

SEE DRAWING ON PRECEDING PAGE

RISER FOR PASS TABLES

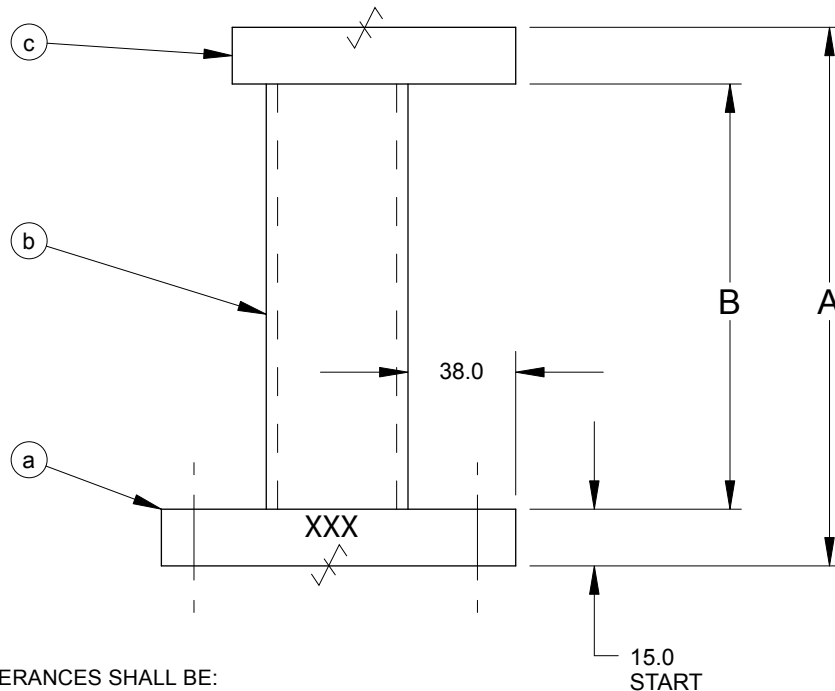
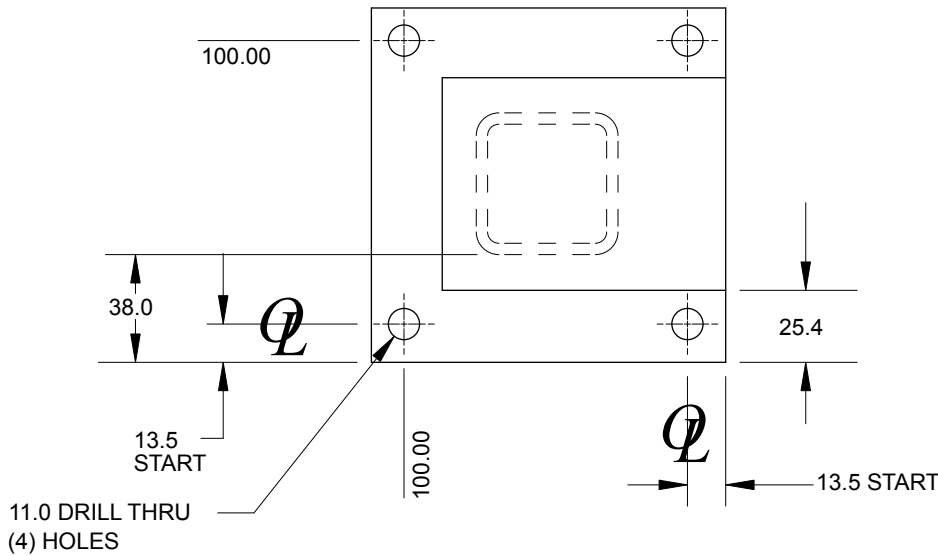

EXCEPT AS NOTED TOLERANCES SHALL BE:

- 1 PLACE MACHINING ± 0.3
- 1 PLACE FABRICATION ± 1.5
- 2 PLACE ± 0.03 GENERAL
- ± 0.03 BETWEEN DOWELS
- ± 0.13 TO SCREW HOLES

NOTES: ALL DIMENSIONS METRIC UNLESS OTHERWISE NOTED.
 WELDED CONSTRUCTION - STRESS RELIEVE
 VENT TO SUIT
 IDENTIFY WITH NAAMS CODE NUMBER
 AS SHOWN XXX

INCH STOCK

- a 1 - HRS ASTM A-36 3/4" X 5" X 5"
- b 1 - STL TBG ASTM A-36 2" X 2" X 3/16" WT X B
- c 1 - HRS ASTM A-36 3/4" X 3" X 4"

METRIC STOCK

- a 1 - HRS ASTM A-36 20MM X 125MM X 125MM
- b 1 - HRS ASTM A-36 50MM X 50MM X 4 WT X B
- c 1 - HRS ASTM A-36 20MM X 75MM X 100MM

A
B

RISER FOR PASS TABLES

NAAMS CODE	A OVERALL HEIGHT	B TUBE HEIGHT
ART060	60.0	30.0
ART070	70.0	40.0
ART080	80.0	50.0
ART090	90.0	60.0
ART100	100.0	70.0
ART110	110.0	80.0
ART120	120.0	90.0
ART130	130.0	100.0
ART140	140.0	110.0
ART150	150.0	120.0
ART160	160.0	130.0
ART170	170.0	140.0
ART180	180.0	150.0
ART190	190.0	160.0
ART200	200.0	170.0
ART210	210.0	180.0
ART220	220.0	190.0
ART230	230.0	200.0
ART240	240.0	210.0
ART250	250.0	220.0
ART260	260.0	230.0
ART270	270.0	240.0
ART280	280.0	250.0
ART290	290.0	260.0
ART300	300.0	270.0
ART310	310.0	280.0
ART320	320.0	290.0
ART330	330.0	300.0

NAAMS CODE	A OVERALL HEIGHT	B TUBE HEIGHT
ART340	340.0	310.0
ART350	350.0	320.0
ART360	360.0	330.0
ART370	370.0	340.0
ART380	380.0	350.0
ART390	390.0	360.0
ART400	400.0	370.0
ART410	410.0	380.0
ART420	420.0	390.0
ART430	430.0	400.0
ART440	440.0	410.0
ART450	450.0	420.0
ART460	460.0	430.0
ART470	470.0	440.0
ART480	480.0	450.0
ART490	490.0	460.0
ART500	500.0	470.0
ART510	510.0	480.0
ART520	520.0	490.0
ART530	530.0	500.0
ART540	540.0	510.0
ART550	550.0	520.0
ART560	560.0	530.0
ART570	570.0	540.0
ART580	580.0	550.0
ART590	590.0	560.0
ART600	600.0	570.0

DROP AWAY LEAF RISER

(TOP MOUNT MACHINE BASE MOUNTING)

Assembly

03/19/21

TOLERANCES:

- 1 PLACE MACHINING ±0.3
- 1 PLACE FABRICATION ±1.5
- 2 PLACE ±0.08 BETWEEN MACHINED SURFACES
 - ±0.03 BETWEEN SINGLE DOWEL AND A HEEL SURFACE
 - ±0.03 BETWEEN DOWELS IN THE SAME PLANE
 - ±0.10 BETWEEN DOWELS IN DIFFERENT PLANES
 - ±0.13 TO SCREW HOLES, NON ACCUMULATIVE

NOTES: ALL DIMENSIONS METRIC UNLESS OTHERWISE NOTED.
WELDED CONSTRUCTION - STRESS RELIEVE VENT TO SUIT
IDENTIFY WITH NAAMS CODE NUMBER AS SHOWN **XXX**

NAAMS CODE	"A" OVERALL DIMENSION	"B" TUBE HEIGHT
ARH300	300.0	255.0
ARH450	450.0	405.0
ARH600	600.0	555.0
ARH750	750.0	705.0
ARH900	900.0	855.0
ARH105	1050.0	1005.0
ARH120	1200.0	1155.0

SEE PAGES N-26.2 THRU N-26.4
FOR MOUNTING OPTIONS

A

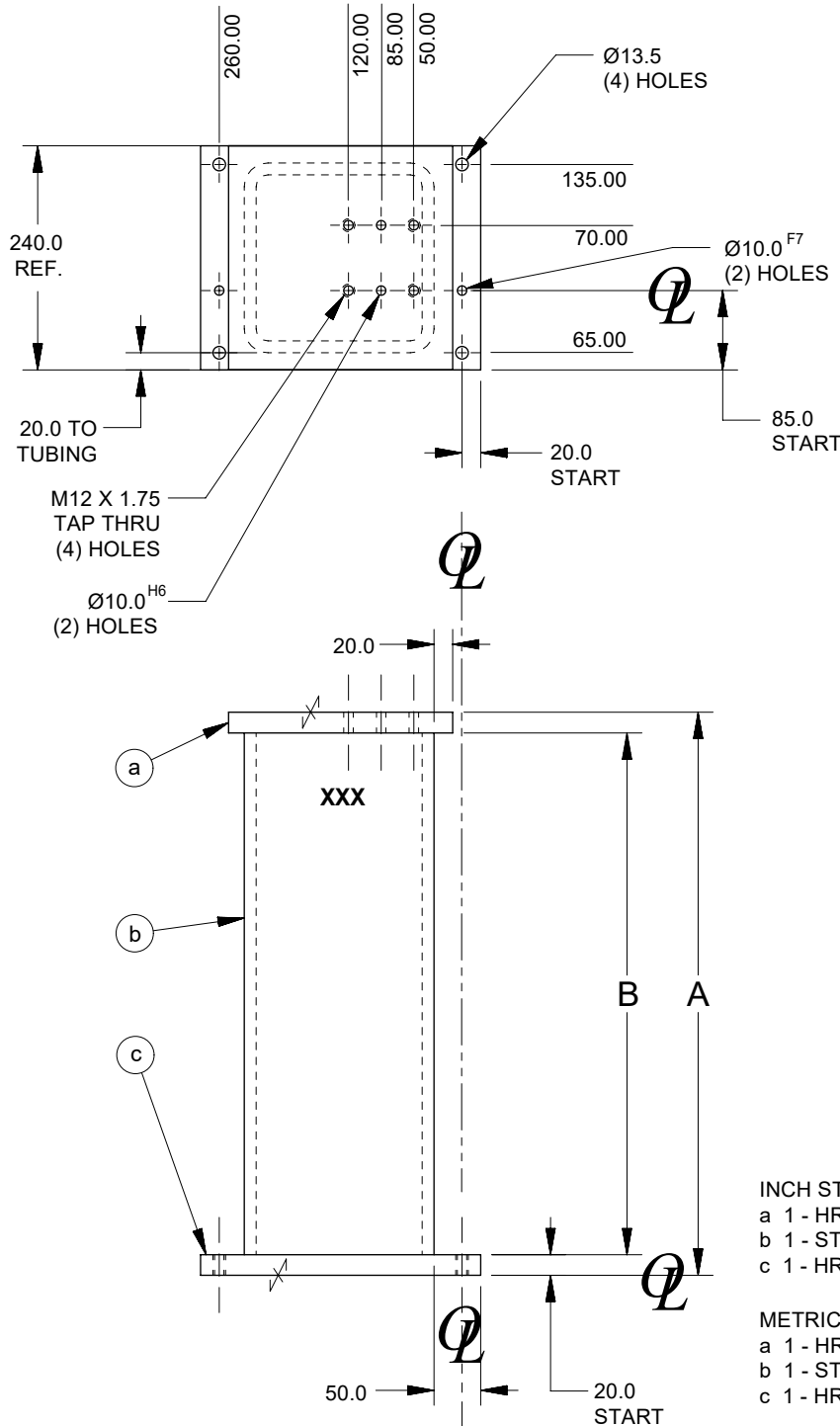

INCH STOCK

- a 1 - HRS ASTM A-36 1" X 9 1/2" X 9 1/2"
- b 1 - STL TBG ASTM A-36 8" X 8" X 1/2" X B
- c 1 - HRS ASTM A-36 1" X 9 1/2" X 12"

METRIC STOCK

- a 1 - HRS ASTM A-36 25MM X 240MM X 240MM
- b 1 - STL TBG ASTM A-36 200MM X 200MM X 13MM X B
- c 1 - HRS ASTM A-36 25MM X 240MM X 300MM

DROP AWAY LEAF RISER

(SIDE MOUNT MACHINE BASE MOUNTING)

Assembly

03/19/21

TOLERANCES:

- 1 PLACE MACHINING ±0.3
- 1 PLACE FABRICATION ±1.5
- 2 PLACE ±0.08 BETWEEN MACHINED SURFACES
 - ±0.03 BETWEEN SINGLE DOWEL AND A HEEL SURFACE
 - ±0.03 BETWEEN DOWELS IN THE SAME PLANE
 - ±0.10 BETWEEN DOWELS IN DIFFERENT PLANES
 - ±0.13 TO SCREW HOLES, NON ACCUMULATIVE

NOTES: ALL DIMENSIONS METRIC UNLESS OTHERWISE NOTED.
 WELDED CONSTRUCTION - STRESS RELIEVE VENT TO SUIT
 IDENTIFY WITH NAAMS CODE NUMBER AS SHOWN **XXX**

NAAMS CODE	"A" DOWEL DIMENSION	"B" TUBE HEIGHT
ARV600	600.0	665.0
ARV750	750.0	815.0
ARV900	900.0	965.0
ARV105	1050.0	1115.0
ARV120	1200.0	1265.0
ARV135	1350.0	1415.0
ARV150	1500.0	1565.0

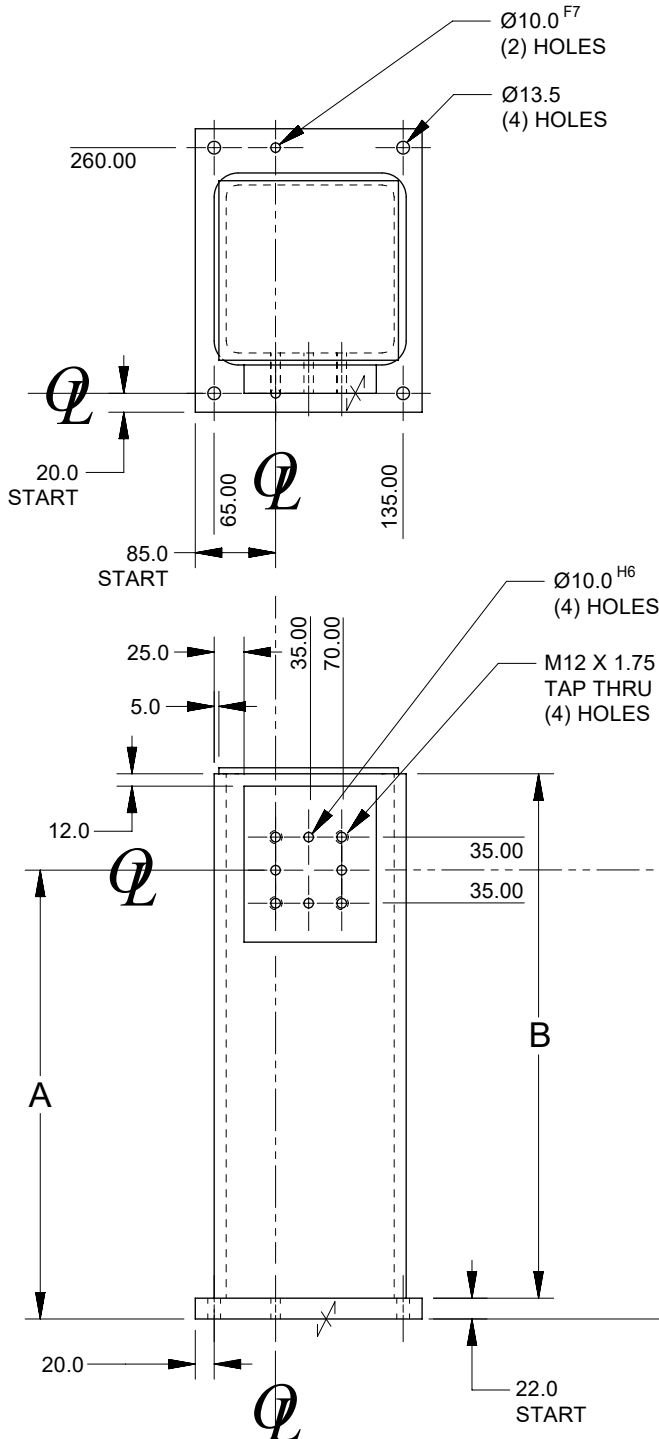

INCH STOCK

- a 1 - HRS ASTM A-36 1/4" X 7 1/2" X 7 1/2"
- b 1 - STL TBG ASTM A-36 8" X 8" X 1/2" X B
- c 1 - HRS ASTM A-36 1 3/8" X 6" X 6"
- d 1 - HRS ASTM A-36 1" X 9 1/2" X 12"

METRIC STOCK

- a 1 - HRS ASTM A-36 6MM X 190MM X 190MM
- b 1 - STL TBG ASTM A-36 200MM X 200MM X 13MM X B
- c 1 - HRS ASTM A-36 35MM X 150MM X 150MM
- d 1 - HRS ASTM A-36 25MM X 240MM X 300MM

SEE PAGES N-26.2 THRU N-26.4 FOR MOUNTING OPTIONS

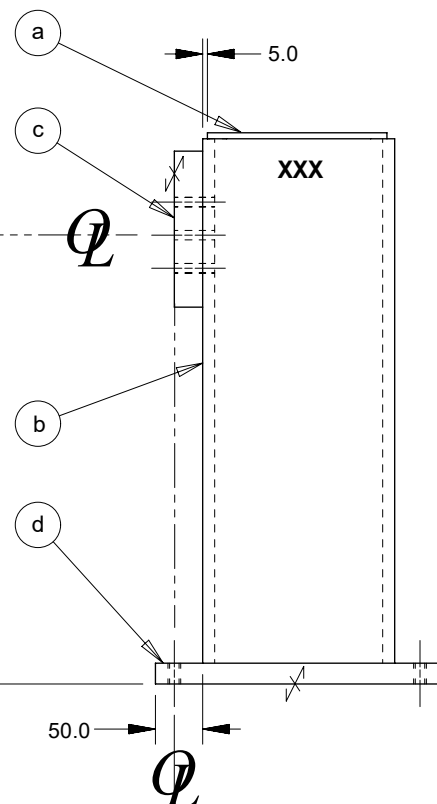

A