

# GUIDE AND GAGE COMPONENTS INDEX

PAGE	DATE	SERIES	DESCRIPTION
<a href="#">G-1</a>	04/22/14		Guide and Gage Components Index
<a href="#">G-1.1</a>	12/02/19		Guide and Gage Components Index
<a href="#">G-1.2</a>	12/14/21		Guide and Gage Components Index
<a href="#">G-2</a>	08/12/97	G01 & G02	Self-Lube Guide Block
<a href="#">G-3</a>	01/03/95	G01	Self-Lube Guide Block (45mm) Coding
<a href="#">G-4</a>	01/03/95	G02	Self-Lube Guide Block (60mm) Coding
<a href="#">G-5</a>	08/12/97	G11	Self-Lube Corner Guide Blocks
<a href="#">G-6</a>	05/19/00	Discontinued	65 mm Wide U & V Blocks
<a href="#">G-7</a>	05/19/00	Discontinued	65 mm Wide U & V Blocks
<a href="#">G-8</a>	05/19/00	Discontinued	75 mm Wide U & V Blocks
<a href="#">G-9</a>	05/19/00	Discontinued	75 mm Wide U & V Blocks
<a href="#">G-10</a>	06/20/03	Discontinued	125 mm Wide U & V Blocks
<a href="#">G-11</a>	05/19/00	Discontinued	125 mm Wide U & V Blocks
<a href="#">G-12</a>	05/19/00	G41, G42 & G43	Center Key Guide and Center Key
<a href="#">G-13</a>	05/19/00	G50	Shoulder Guide Post/Pin
<a href="#">G-14</a>	05/19/00	G50	Shoulder Guide Post/Pin Coding
<a href="#">G-15</a>	05/19/00	G51	Guide Post/Pin
<a href="#">G-16</a>	10/17/05	G51	Guide Post/Pin Coding
<a href="#">G-17</a>	04/10/15	G61	Guide Post/Pin Bronze Bushing
<a href="#">G-18</a>	04/10/15	G71	Bronze Pad Bushing
<a href="#">G-19</a>	04/10/15	Discontinued	Bushing Toe Clamp
<a href="#">G-20</a>	08/09/17	G72 & G73	Bushing Clamping Procedures
<a href="#">G-21</a>	05/19/00	G81	Finger Gage
<a href="#">G-22</a>	05/19/00	Discontinued	Balancing Cones
<a href="#">G-23</a>	05/19/00	Discontinued	Balancing Cones Coding
<a href="#">G-24</a>	10/19/01	G82	Disappearing Gage
<a href="#">G-25</a>	04/14/15	Discontinued	175 mm Wide U & V Blocks
<a href="#">G-26</a>	04/14/15	Discontinued	175 mm Wide U & V Blocks

# GUIDE AND GAGE COMPONENTS INDEX

PAGE	DATE	SERIES	DESCRIPTION
<a href="#">G-27</a>	12/19/12		Blank Page
<a href="#">G-28</a>	12/19/12		Blank Page
<a href="#">G-29</a>	12/19/12		Blank Page
<a href="#">G-30</a>	12/19/12		Blank Page
<a href="#">G-31</a>	12/19/12		Blank Page
<a href="#">G-32</a>	12/19/12		Blank Page
<a href="#">G-33</a>	12/19/12		Blank Page
<a href="#">G-34</a>	01/29/13		Blank Page
<a href="#">G-35</a>	01/29/13		Blank Page
<a href="#">G-36</a>	08/01/11	G56	Blank Crowder
<a href="#">G-37</a>	08/01/11	G56	Blank Crowder
<a href="#">G-38</a>	08/01/11		Blank Page
<a href="#">G-39</a>	08/01/11		Blank Page
<a href="#">G-40</a>	08/01/11	G95	Trim Tab Pilot Gage
<a href="#">G-41</a>	08/01/11	G95	Trim Tab Pilot Gage
<a href="#">G-42</a>	08/01/11	G95	Trim Tab Pilot Gage
<a href="#">G-43</a>	08/01/11	G95	Trim Tab Pilot Gage
<a href="#">G-44</a>	08/01/11	G95	Trim Tab Pilot Gage
<a href="#">G-45</a>	08/01/11	G95	Trim Tab Pilot Gage
<a href="#">G-46</a>	12/19/12	G96	Adjustable Bar Gage/Sensor
<a href="#">G-47</a>	12/19/12	G96	Adjustable Bar Gage/Sensor
<a href="#">G-48</a>	12/19/12	G96	Adjustable Bar Gage/Sensor
<a href="#">G-49</a>	04/23/14	G97	65 mm V Block
<a href="#">G-50</a>	04/23/14	G98	65 mm U Block
<a href="#">G-51</a>	04/23/14	G99	125 mm V Block
<a href="#">G-52</a>	04/23/14	G100	125 mm U Block
<a href="#">G-53</a>	06/13/17	Discontinued	Guide Pin Bushing Toe Clamps
<a href="#">G-54</a>	04/14/15	G103	Balancing Cones

# GUIDE AND GAGE COMPONENTS INDEX

PAGE	DATE	SERIES	DESCRIPTION
<a href="#">G-55</a>	04/14/15	G103	Balancing Cone Shim & Coding
<a href="#">G-56</a>	06/10/17	G104	Ø50 HD Guide Keeper
<a href="#">G-57</a>	06/10/17	G104	Ø50 HD Guide Keeper
<a href="#">G-58</a>	06/10/17	G104	Ø50 HD Guide Keeper
<a href="#">G-59</a>	06/10/17	G104	Ø50 HD Guide Keeper
<a href="#">G-60</a>	06/10/17	G104	Ø50 HD Guide Keeper
<a href="#">G-61</a>	06/24/17	G105	Ø36 HD Guide Keeper
<a href="#">G-62</a>	06/24/17	G105	Ø36 HD Guide Keeper
<a href="#">G-63</a>	06/24/17	G105	Ø36 HD Guide Keeper
<a href="#">G-64</a>	06/24/17	G105	Ø36 HD Guide Keeper
<a href="#">G-65</a>	06/24/17	G105	Ø36 HD Guide Keeper
<a href="#">G-66</a>	06/25/17	G106	Ø65 HD Guide Keeper
<a href="#">G-67</a>	06/25/17	G106	Ø65 HD Guide Keeper
<a href="#">G-68</a>	06/25/17	G106	Ø65 HD Guide Keeper
<a href="#">G-69</a>	06/25/17	G106	Ø65 HD Guide Keeper
<a href="#">G-70</a>	06/25/17	G106	Ø65 HD Guide Keeper
<a href="#">G-71</a>	03/19/21	G107	Panel Blank Support Assembly
<a href="#">G-72</a>	03/19/21	G107	Panel Blank Support Assembly Index
<a href="#">G-73</a>	03/19/21	G107	Mounting Block
<a href="#">G-74</a>	03/19/21	G107	Blank Support Pin
<a href="#">G-75</a>	03/19/21	G107	Guide / Keeper Block
<a href="#">G-76</a>	03/19/21	G107	Pusher Plate
<a href="#">G-77</a>	12/14/21	G108	Shim - Balance Block
<a href="#">G-78</a>	12/14/21	G109	Shim - Wear Plate
<a href="#">G-79</a>	12/14/21	G109	Shim - Wear Plate Coding

# SELF-LUBE GUIDE BLOCKS

(G01 & G02 SERIES)

Stamping

08/12/97

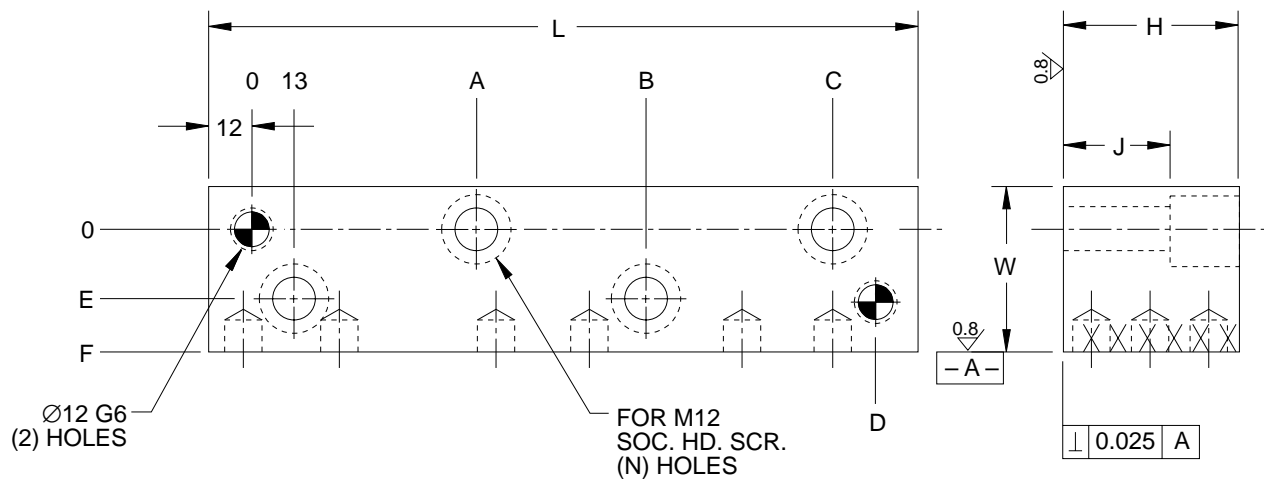

GRAPHITE PLUGS  
THIS SURFACE

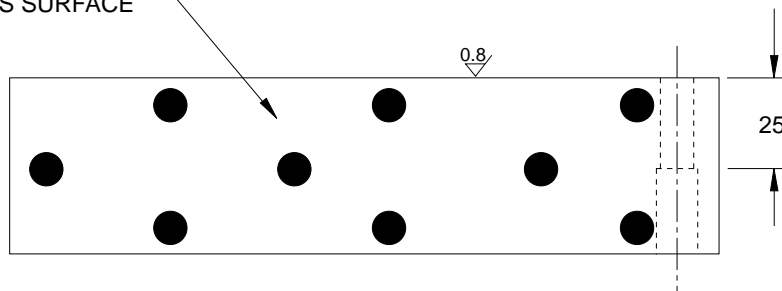

## NOTES & SPECIFICATIONS:

Screw hole locations  $\pm 0.25$

Dowel hole locations  $\pm 0.10$

Break all sharp edges  $0.4 \times 45^\circ$

Material, steel. Surface harden cross-hatched areas.

Evenly distributed graphite plugs to cover 20-30% of the area that requires lubrication.

*CODING ON FOLLOWING PAGE*

A



# SELF-LUBE GUIDE BLOCK CODING

(G01 SERIES)

Stamping

01/03/95

## 45 mm WIDE

NAAMS CODE	(N) HOLES	L	A	B	C	D	E	F	H	J	W	
G014007	2	75	-	-	38	51	18	33	40	15		
G014010	2	100	-	-	63	76						
G014012	3	125	-	50.5	88	101						
G014015	3	150	-	63	113	126						
G014017	3	175	-	75.5	138	151						
G014020	4	200	63	113	163	176						
G014022	4	225	73	128	188	201						
G014025	4	250	83	153	213	226						
G014507	2	75	-	-	38	51	18	33	45	25		
G014510	2	100	-	-	63	76						
G014512	3	125	-	50.5	88	101						
G014515	3	150	-	63	113	126						
G014517	3	175	-	75.5	138	151						
G014520	4	200	63	113	163	176						
G014522	4	225	73	128	188	201						
G014525	4	250	83	153	213	226						
G015007	2	75	-	-	38	51	18	33	50	30		45
G015010	2	100	-	-	63	76						
G015012	3	125	-	50.5	88	101						
G015015	3	150	-	63	113	126						
G015017	3	175	-	75.5	138	151						
G015020	4	200	63	113	163	176						
G015022	4	225	73	128	188	201						
G015025	4	250	83	153	213	226						
G016007	2	75	-	-	38	51	18	33	60	30		
G016010	2	100	-	-	63	76						
G016012	3	125	-	50.5	88	101						
G016015	3	150	-	63	113	126						
G016017	3	175	-	75.5	138	151						
G016020	4	200	63	113	163	176						
G016022	4	225	73	128	188	201						
G016025	4	250	83	153	213	226						
G017507	2	75	-	-	38	51	18	33	75	30		
G017510	2	100	-	-	63	76						
G017512	3	125	-	50.5	88	101						
G017515	3	150	-	63	113	126						
G017517	3	175	-	75.5	138	151						
G017520	4	200	63	113	163	176						
G017522	4	225	73	128	188	201						
G017525	4	250	83	153	213	226						

CODING CONTINUED ON FOLLOWING PAGE

# SELF-LUBE GUIDE BLOCK CODING

(G02 SERIES)

Stamping

01/03/95

## 60 mm WIDE

NAAMS CODE	(N) HOLES	L	A	B	C	D	E	F	H	J	W
G025007	2	75	–	–	38	51	33	48	50	30	60
G025010	2	100	–	–	63	76					
G025012	3	125	–	50.5	88	101					
G025015	3	150	–	63	113	126					
G025017	3	175	–	75.5	138	151					
G025020	4	200	63	113	163	176					
G025022	4	225	73	128	188	201					
G025025	4	250	83	153	213	226					
G026007	2	75	–	–	38	51	33	48	60	30	
G026010	2	100	–	–	63	76					
G026012	3	125	–	50.5	88	101					
G026015	3	150	–	63	113	126					
G026017	3	175	–	75.5	138	151					
G026020	4	200	63	113	163	176					
G026022	4	225	73	128	188	201					
G026025	4	250	83	153	213	226					
G028007	2	75	–	–	38	51	33	48	80	30	
G028010	2	100	–	–	63	76					
G028012	3	125	–	50.5	88	101					
G028015	3	150	–	63	113	126					
G028017	3	175	–	75.5	138	151					
G028020	4	200	63	113	163	176					
G028022	4	225	73	128	188	201					
G028025	4	250	83	153	213	226					
G020007	2	75	–	–	38	51	33	48	100	30	
G020010	2	100	–	–	63	76					
G020012	3	125	–	50.5	88	101					
G020015	3	150	–	63	113	126					
G020017	3	175	–	75.5	138	151					
G020020	4	200	63	113	163	176					
G020022	4	225	73	128	188	201					
G020025	4	250	83	153	213	226					

# SELF-LUBE CORNER GUIDE BLOCKS

(G11 SERIES)

GLOBAL STANDARD COMPONENTS



Stamping

08/12/97

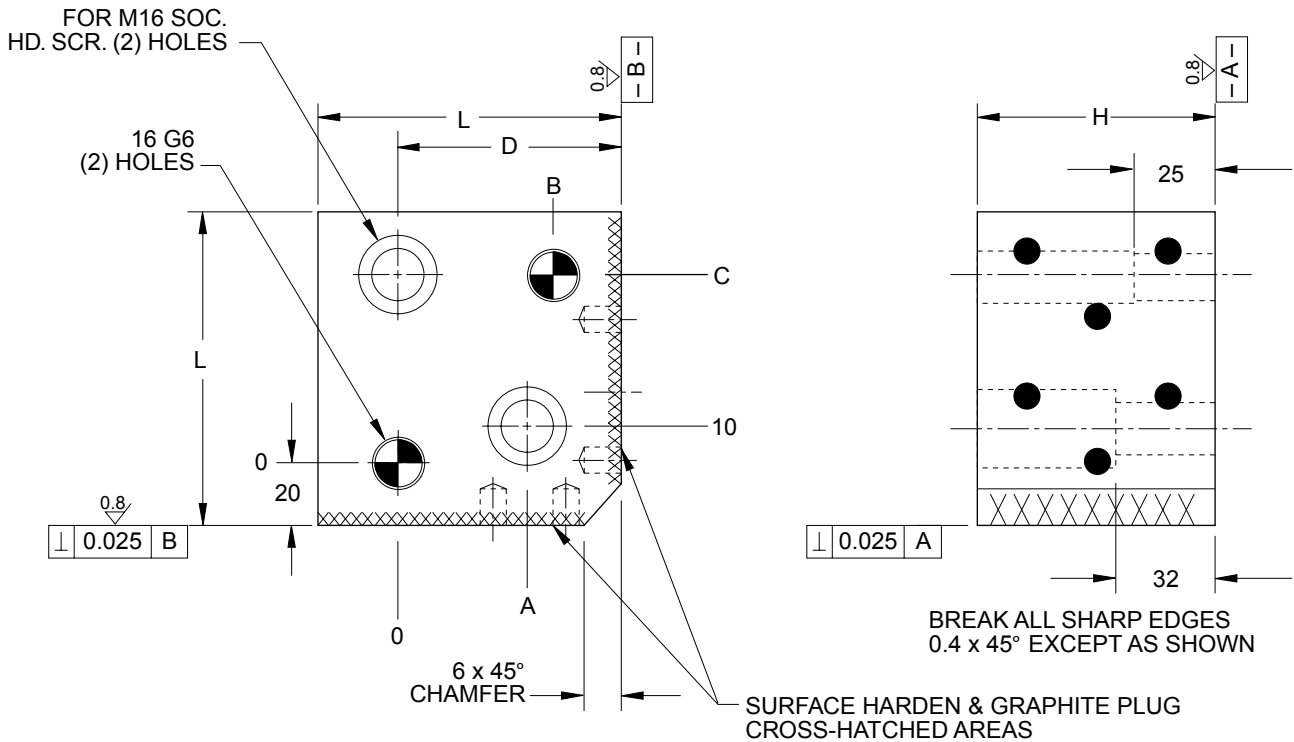

A

NAAMS CODE	H	A	B	C	D	L
G118007	75	25	35	40	55	80
G118010	100					
G118012	125					
G119507	75	40	50	55	70	95
G119510	100					
G119512	125					
G111207	75	65	75	80	95	120
G111210	100					
G111212	125					

**NOTES & SPECIFICATIONS:**

Screw hole locations ±0.25

Dowel hole locations ±0.10

Material, steel. Grind as shown.

Evenly distributed graphite plugs to cover 20–30% of the area that requires lubrication.

# 65 mm WIDE U & V BLOCKS

(G15 SERIES)

GLOBAL STANDARD COMPONENTS



Stamping

05/19/00

## FEMALE "U" BLOCK

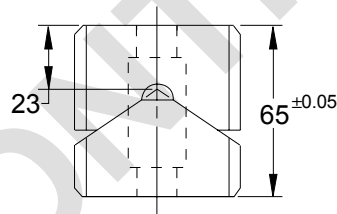
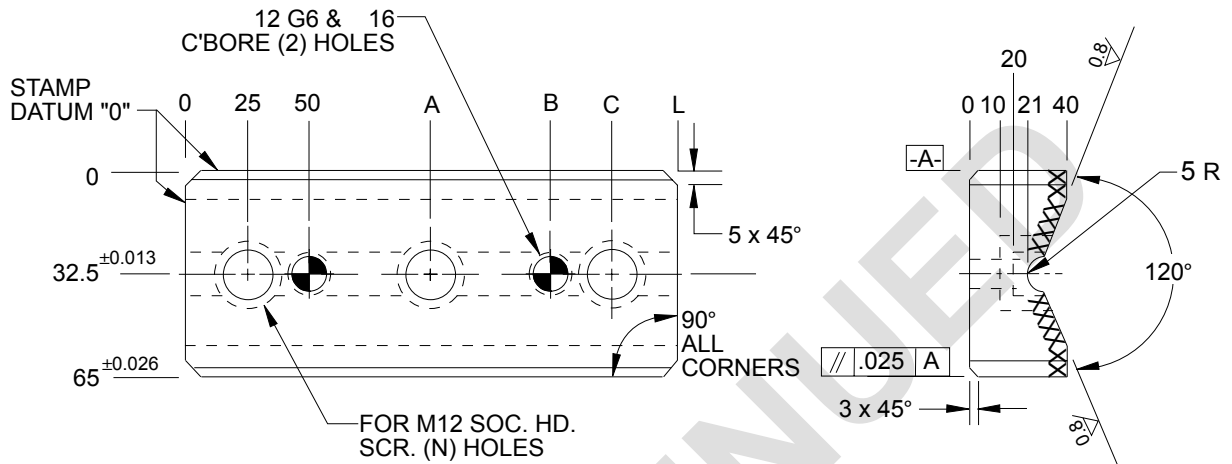

TYPICAL SECTION  
"U" & "V" BLOCK ASSEMBLY

FEMALE "U" BLOCK					
NAAMS CODE	L	A	B	C	N
G157515	150	-	100	125	2
G157520	200	-	150	175	2
G157525	250	125	200	225	3
G157530	300	150	250	275	3

### NOTES & SPECIFICATIONS:

Material, steel

Surface harden cross-hatched areas.

Tolerance between screw holes  $\pm 0.12$

Tolerance between dowel holes  $\pm 0.10$

<sup>1.6</sup> All over except where otherwise stated.

Break all sharp corners.

A

# 65 mm WIDE U & V BLOCKS

(G16 & G17 SERIES)

GLOBAL STANDARD COMPONENTS



Stamping

05/19/00

## MALE "V" BLOCK

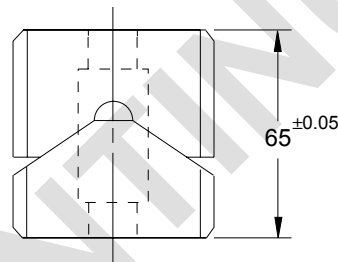
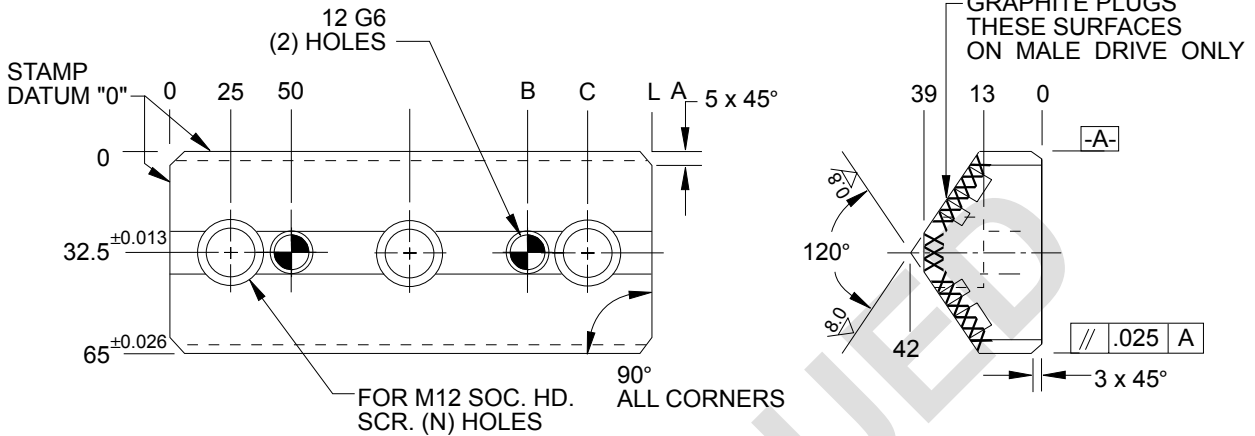

TYPICAL SECTION  
"U" & "V" BLOCK ASSEMBLY

MALE "V" BLOCK						
NAAMS CODE(X)	NAAMS CODE(Y)	L	A	B	C	N
G167515	G177515	150	-	100	125	2
G167520	G177520	200	-	150	175	2
G167525	G177525	250	125	200	225	3
G167530	G177530	300	150	250	275	3

### NOTES & SPECIFICATIONS:

Material, steel or bronze

Use code X for steel

Use code Y for bronze

Surface harden cross-hatched areas on steel.

Tolerance between screw holes ±0.12

Tolerance between dowel holes ±0.10

<sup>1.6</sup> All over except where otherwise stated.

Break all sharp corners

Male "V" driver requires evenly distributed graphite plugs to cover 20-30% of the surface that requires lubrication

A

B

# 75 mm WIDE U & V BLOCKS

(G21 SERIES)

GLOBAL STANDARD COMPONENTS



Stamping

05/19/00

## FEMALE "U" BLOCK

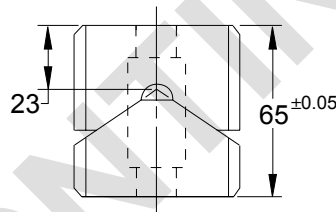
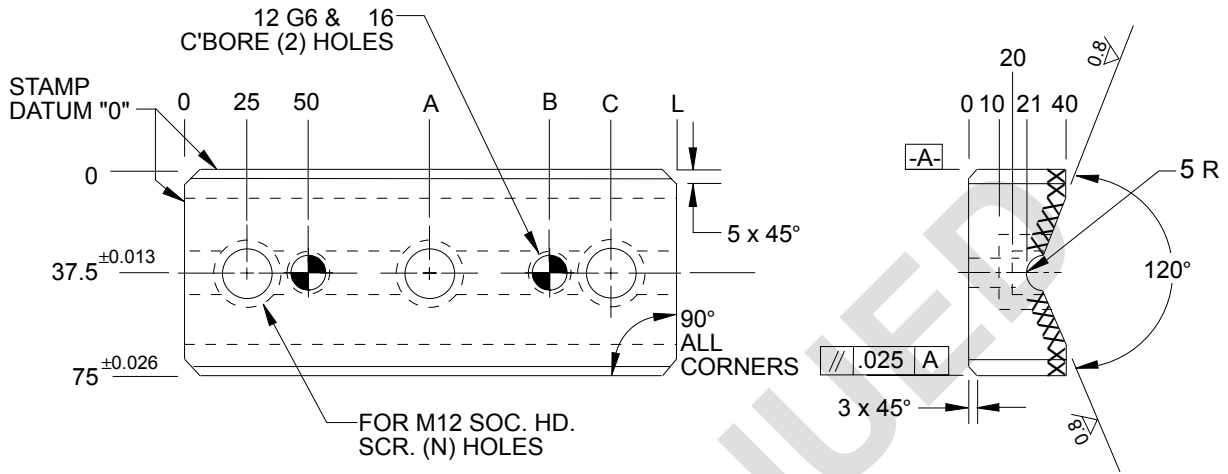

TYPICAL SECTION  
"U" & "V" BLOCK ASSEMBLY

FEMALE "U" BLOCK					
NAAMS CODE	L	A	B	C	N
G217515	150	-	100	125	2
G217520	200	-	150	175	2
G217525	250	125	200	225	3
G217530	300	150	250	275	3

### NOTES & SPECIFICATIONS:

Material, steel

Surface harden cross-hatched areas.

Tolerance between screw holes  $\pm 0.12$

Tolerance between dowel holes  $\pm 0.10$

<sup>1.6</sup> All over except where otherwise stated.

Break all sharp corners.

A

B

# 75 mm WIDE U & V BLOCKS

(G22 & G23 SERIES)

GLOBAL STANDARD COMPONENTS



Stamping

05/19/00

## MALE "V" BLOCK

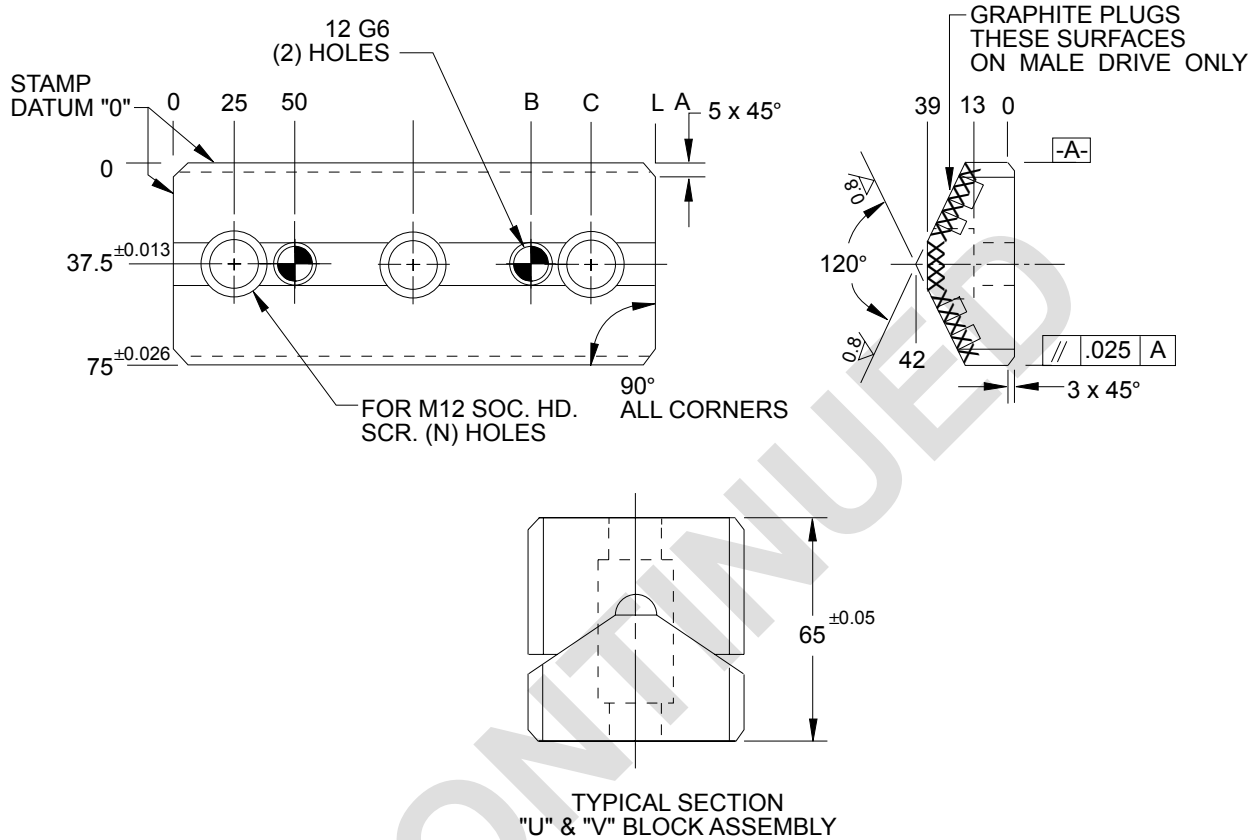

MALE "V" BLOCK						
NAAMS CODE(X)	NAAMS CODE(Y)	L	A	B	C	N
G227515	G237515	150	-	100	125	2
G227520	G237520	200	-	150	175	2
G227525	G237525	250	125	200	225	3
G227530	G237530	300	150	250	275	3

### NOTES & SPECIFICATIONS:

Material, steel or bronze

Use code X for steel

Use code Y for bronze

Surface harden cross-hatched areas on steel.

Tolerance between screw holes ±0.12

Tolerance between dowel holes ±0.10

<sup>1.6</sup> All over except where otherwise stated.

Break all sharp corners

Male "V" driver requires evenly distributed graphite plugs to cover 20-30% of the surface that requires lubrication

A

B

# 125 mm WIDE U & V BLOCKS

( G31 SERIES)

Stamping

06/20/03

## FEMALE "U" BLOCK

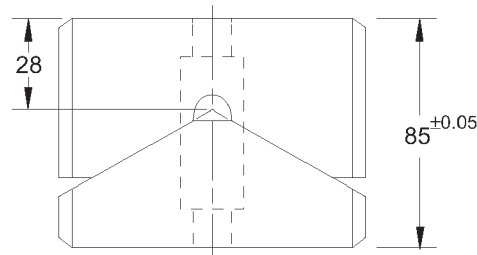
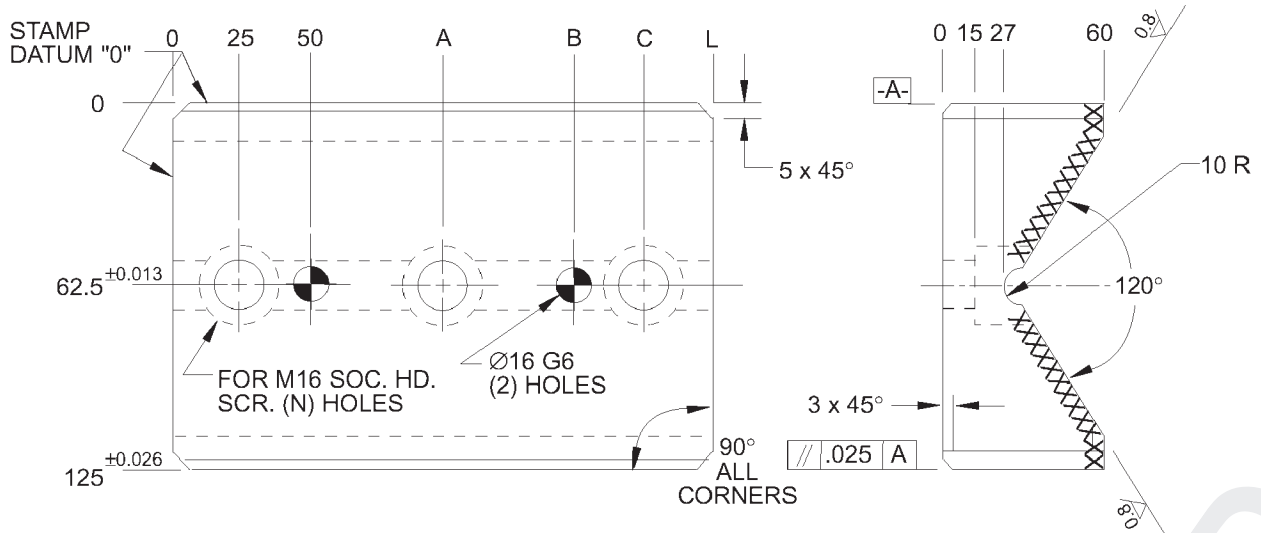

"U" & "V" BLOCK ASSEMBLY

FEMALE "U" BLOCK					
NAAMS CODE	L	A	B	C	N
G311215	150	-	100	125	2
G311220	200	-	150	175	2
G311225	250	125	200	225	3
G311230	300	150	250	275	3

### NOTES & SPECIFICATIONS:

Material, steel

Surface harden cross-hatched areas.

Tolerance between screw holes  $\pm 0.12$

Tolerance between dowel holes  $\pm 0.10$

<sup>1.6</sup> All over except where otherwise stated.

Break all sharp corners.

C

A

B



# 125 mm WIDE U & V BLOCKS

(G32 & G33 SERIES)

GLOBAL STANDARD COMPONENTS



Stamping

05/19/00

## MALE "V" BLOCK

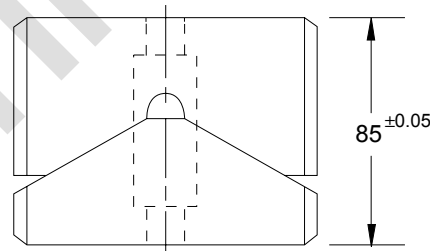
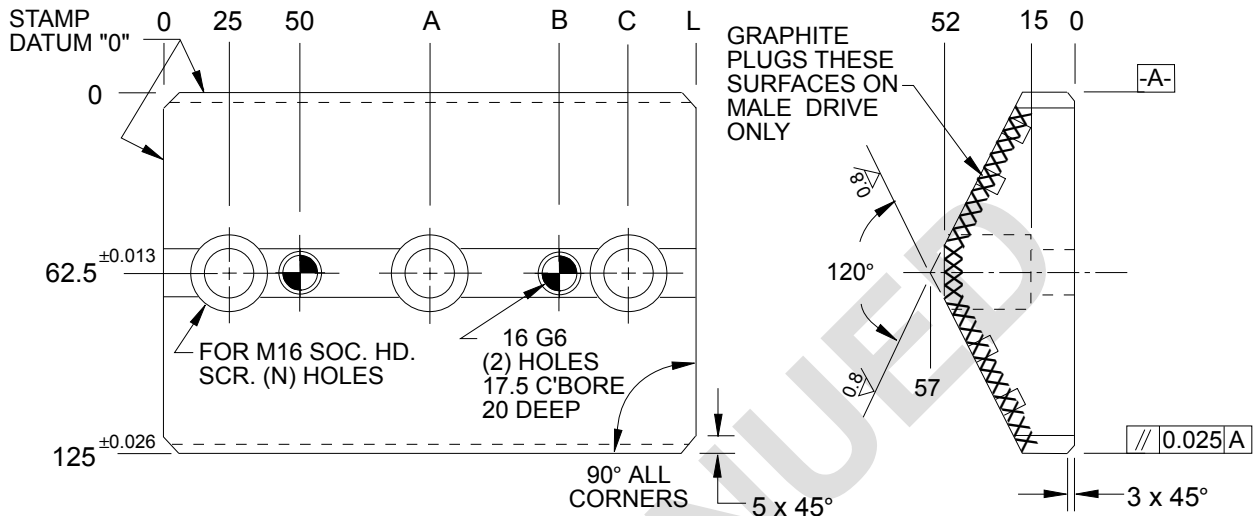

"U" & "V" BLOCK ASSEMBLY

MALE "V" BLOCK						
NAAMS CODE(X)	NAAMS CODE(Y)	L	A	B	C	N
G321215	G331215	150	—	100	125	2
G321220	G331220	200	—	150	175	2
G321225	G331225	250	125	200	225	3
G321230	G331230	300	150	250	275	3

### NOTES & SPECIFICATIONS:

Material, steel or bronze

Use code X for steel

Use code Y for bronze

Surface harden cross-hatched areas on steel.

Tolerance between screw holes  $\pm 0.12$

Tolerance between dowel holes  $\pm 0.10$

<sup>1.6</sup> All over except where otherwise stated.

Break all sharp corners

Male "V" driver requires evenly distributed graphite plugs to cover 20–30% of the surface that requires lubrication

A

B

# CENTER KEY GUIDE AND CENTER KEY

(G41, G42 & G43 SERIES)

GLOBAL STANDARD COMPONENTS



Stamping

05/19/00

## CENTER KEY GUIDE (G41)

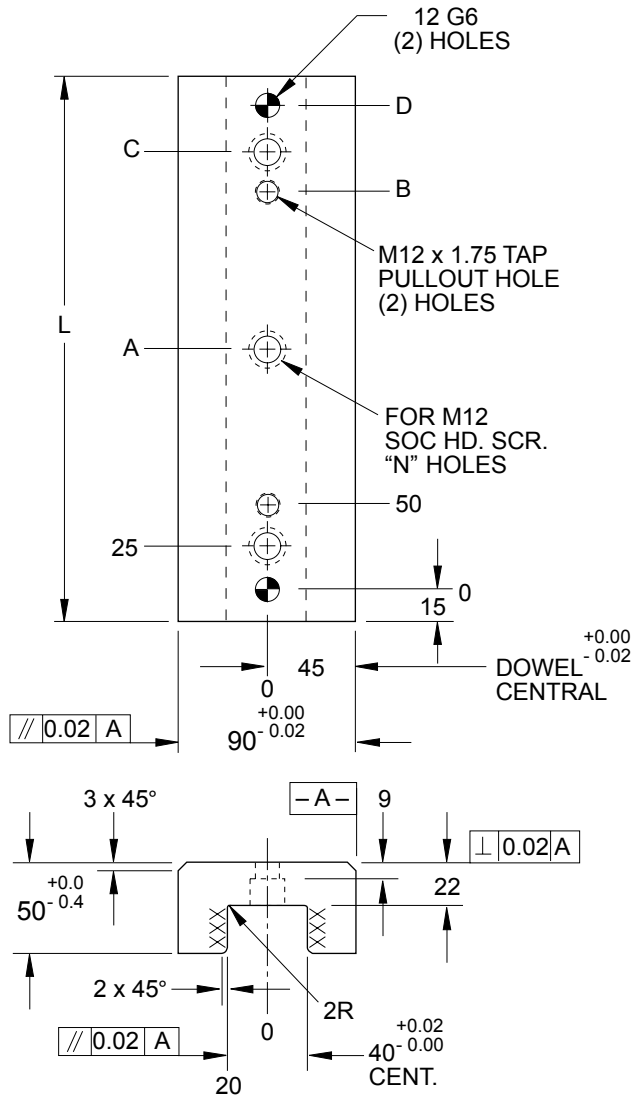

## CENTER KEY (G42 & G43)

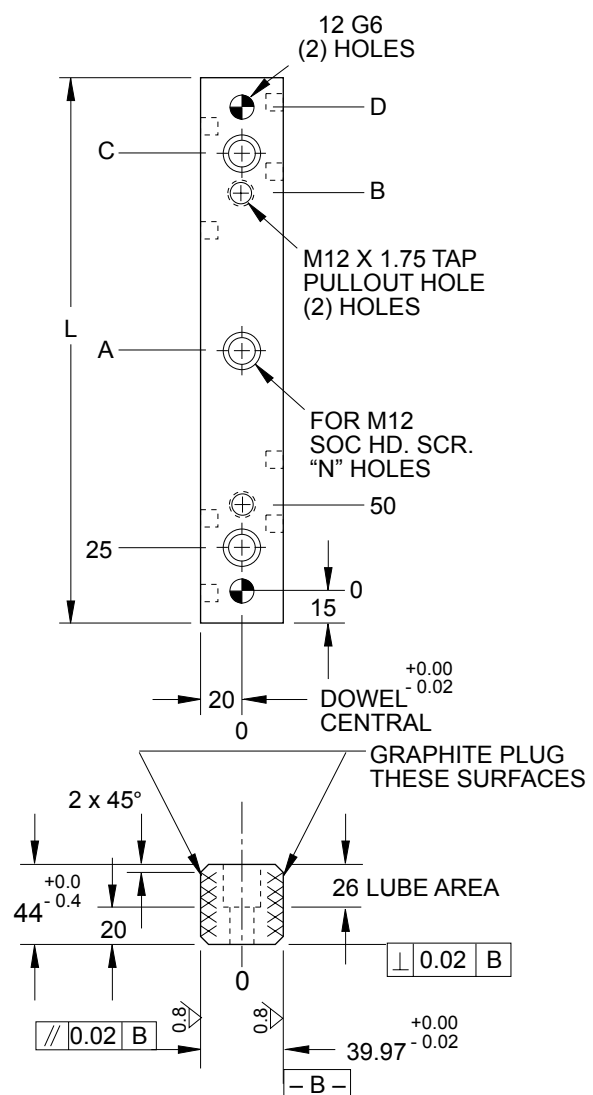

NAAMS CODE(X)	NAAMS CODE(Y)	A	B	C	D	L	"N"
G419020		-	120	145	170	200	2
G419030		135	220	245	270	300	3
G424020	G434020	-	120	145	170	200	2
G424030	G434030	135	220	245	270	300	3

Use Code X for steel, Code Y for bronze.

### NOTES & SPECIFICATIONS:

Tolerance between screw holes  $\pm 0.25$

Tolerance between dowel holes  $\pm 0.10$

Material, steel or bronze. Surface harden cross-hatched areas on steel.

Evenly distributed graphite plugs to cover 20-30% of the area that requires lubrication.

A

B

# SHOULDER GUIDE POST/PIN

(G50 SERIES)

GLOBAL STANDARD COMPONENTS

TM **NAAMS**



Stamping

05/19/00

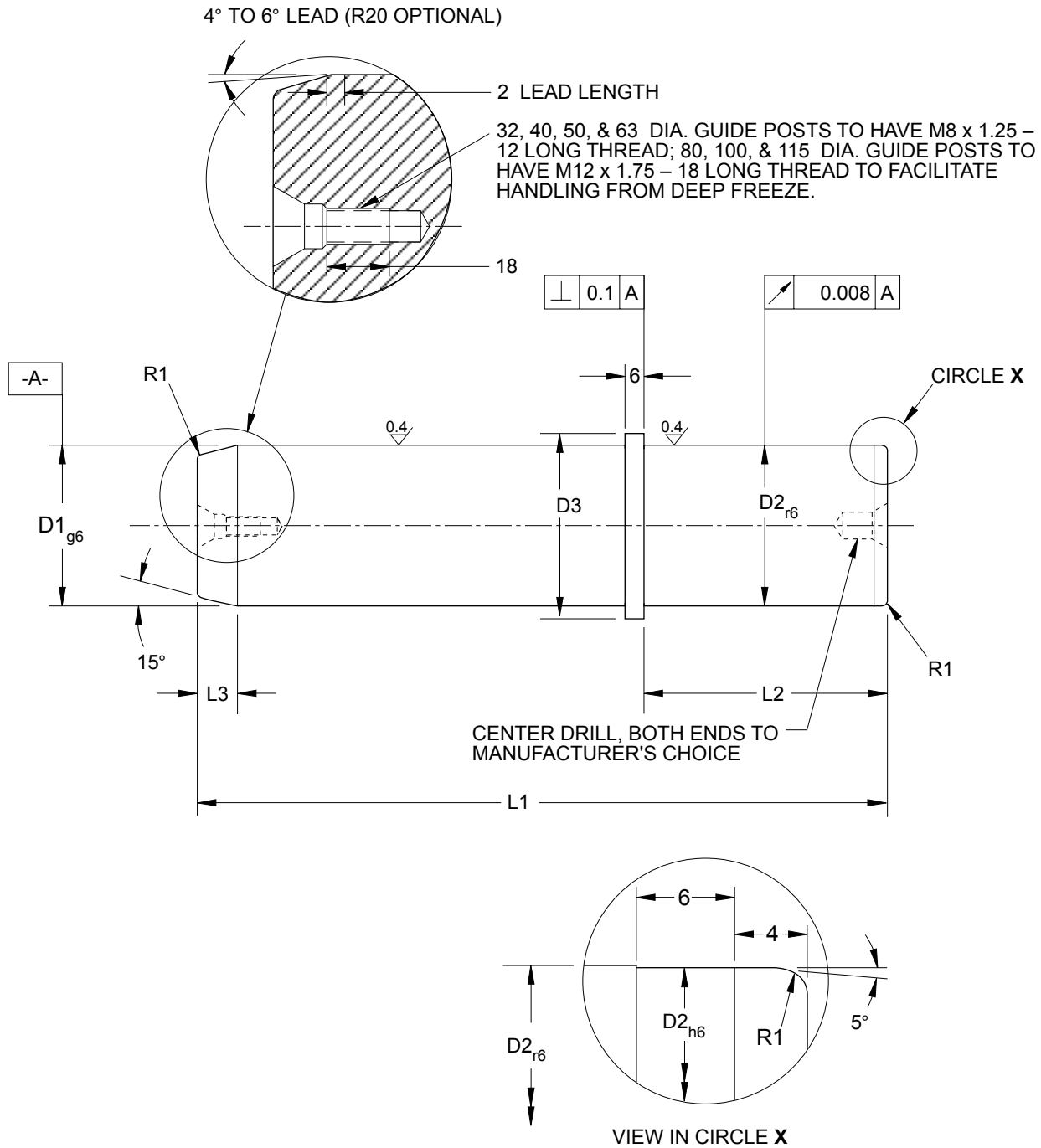

A

A

B

# SHOULDER GUIDE POST/PIN CODING

(G50 SERIES)

NAAMS CODE	D1	D2	D3	L1	L2	L3	R1
G504016	40	40	50	160	56	8	2
G504018				180			
G504020				200			
G504022				225			
G504025				250			
G505016	50	50	63	160	70	10	2.5
G505018				180			
G505020				200			
G505022				225			
G505025				250			
G505028				280			
G505031	315						
G506320	63	63	80	200	80	10	2.5
G506322				225			
G506325				250			
G506328				280			
G506331				315			
G506335				355			
G506340	400						
G508025	80	80	100	250	100	10	3
G508028				280			
G508031				315			
G508035				355			
G508040				400			
G501031	100	100	125	315	125	10	3
G501035				355			
G501040				400			

A

B

# GUIDE POST/PIN

(G51 SERIES)

GLOBAL STANDARD COMPONENTS



Stamping

05/19/00

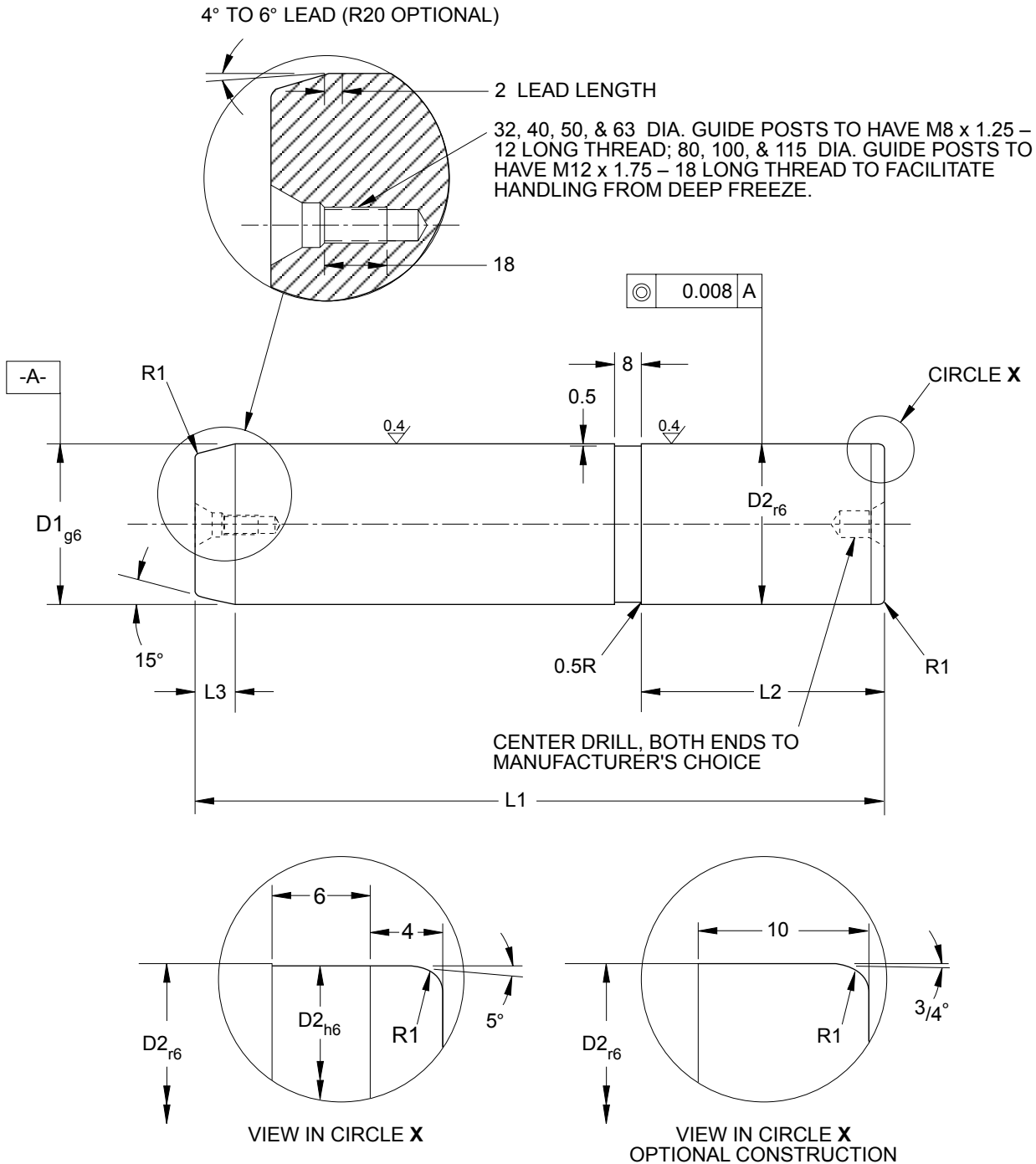

**NOTES & SPECIFICATIONS:**

Hardened steel

CODING ON FOLLOWING PAGE

**A**

# GUIDE POST/PIN CODING

( G51 SERIES)

GLOBAL STANDARD COMPONENTS



Stamping

10/17/05

NAAMS CODE	D1	D2	L1	L2	L3	R1
G512508	25	25	80	40	8	2
G512510			100			
G512512			125			
G512514			140			
G512516			160			
G512518			180			
G513210	32	32	100	45	8	2
G513212			125			
G513214			140			
G513216			160			
G513218			180			
G513220			200			
G514016	40	40	160	56	8	2
G514018			180			
G514020			200			
G514022			225			
G514025			250			
G515016	50	50	160	70	10	2.5
G515018			180			
G515020			200			
G515022			225			
G515025			250			
G515028			280			
G515031			315			
G516320	63	63	200	80	10	2.5
G516322			225			
G516325			250			
G516328			280			
G516331			315			
G516335			355			
G516340			400			
G516350			500			
G518025			80			
G518028	280					
G518031	315					
G518035	355					
G518040	400					
G518050	500					
G511031	100	100	315	125	10	3
G511035			355			
G511040			400			
G511050			500			
G511140	115	115	400	140	10	3
G511150			500			
G511240	125	125	400	140	10	3
G511245			450			
G511250			500			
G511255			550			
G511260			600			
G511265			650			
G511270			700			

C

D

A

B



# BRONZE PAD BUSHING

(G71 SERIES)

GLOBAL STANDARD COMPONENTS



Stamping

04/10/15

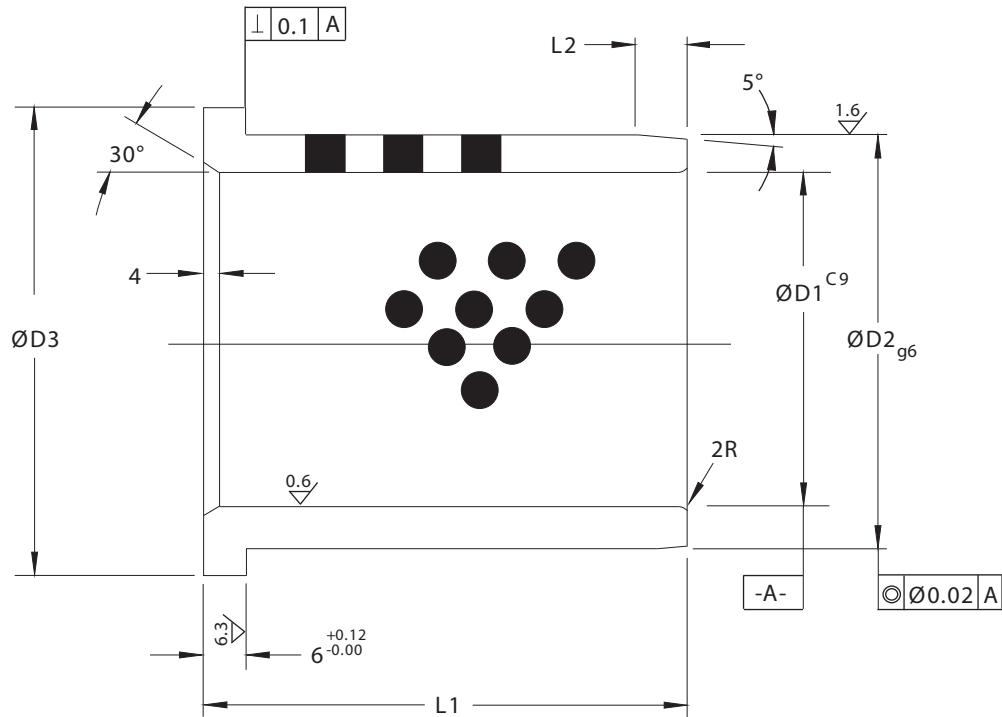

NAAMS CODE	D1	D2	D3	L1	L2
G712540	25	32	40	40	4
G713250	32	40	50	50	4
G714055	40	50	63	55	5
G715063	50	63	71	63	6
G716375	63	80	90	75	8
G718090	80	100	112	90	10
G711011	100	125	140	115	12
G711213	125	160	180	138	12

## NOTES & SPECIFICATIONS:

- Order bushing clamps separately.
- Evenly distributed graphite to cover 20-30% of the sliding surface.
- Graphite to be positioned to insure overlapping in the slide direction.

C

B

D

A



# BUSHING TOE CLAMP

(G72 AND G73 SERIES)

GLOBAL STANDARD COMPONENTS



Stamping

04/10/15

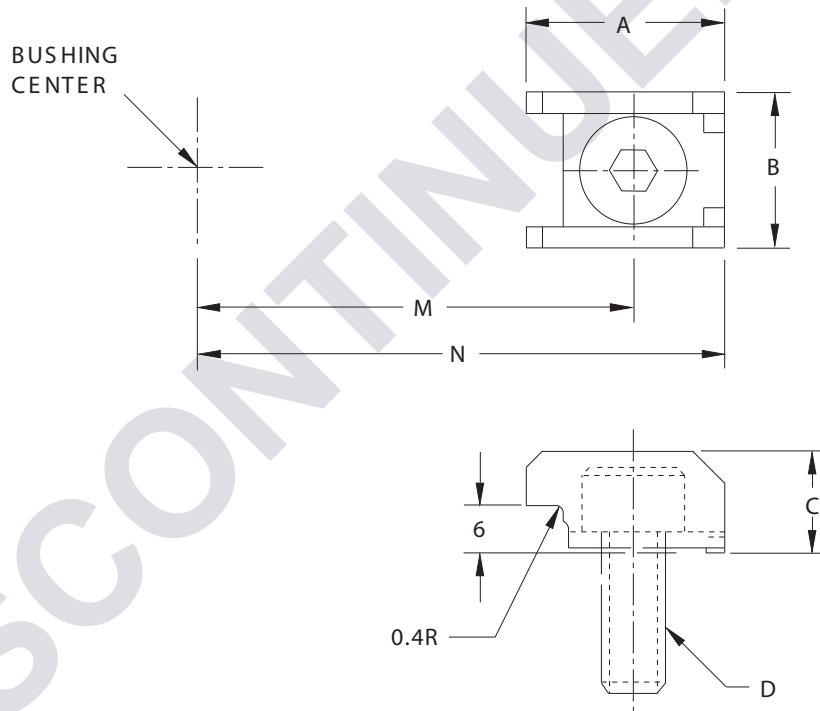

NAAMS CODE  
G720000

NAAMS CODE  
G730000

A = 24.6  
B = 18.9  
C = 13  
D = M8 x 1.25 x 20

A = 27.9  
B = 23.5  
C = 15.5  
D = M10 x 1.5 x 20

NOM POST DIA	M	N
25	29	40.1
32	34	45.1
40	40.5	51.6
50	44.5	55.6
63	54	65.1
80	65	76.1
100	79	90.1
115	86.5	97.6

NOM POST DIA	M	N
25	30.5	43.4
32	35.5	48.4
40	42	54.9
50	46	58.9
63	55.5	68.4
80	66.5	79.4
100	80.5	93.4
115	88	100.9
125	100.5	113.4

## NOTES & SPECIFICATIONS:

Each clamp must withstand 10,000 newtons pull

B

A

# BUSHING CLAMPING PROCEDURES

(G72 and G73 SERIES)

GLOBAL STANDARD COMPONENTS



Stamping

08/09/17

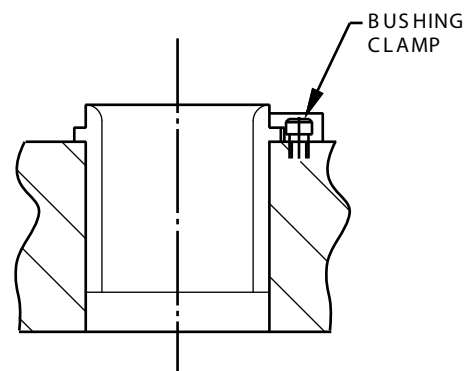
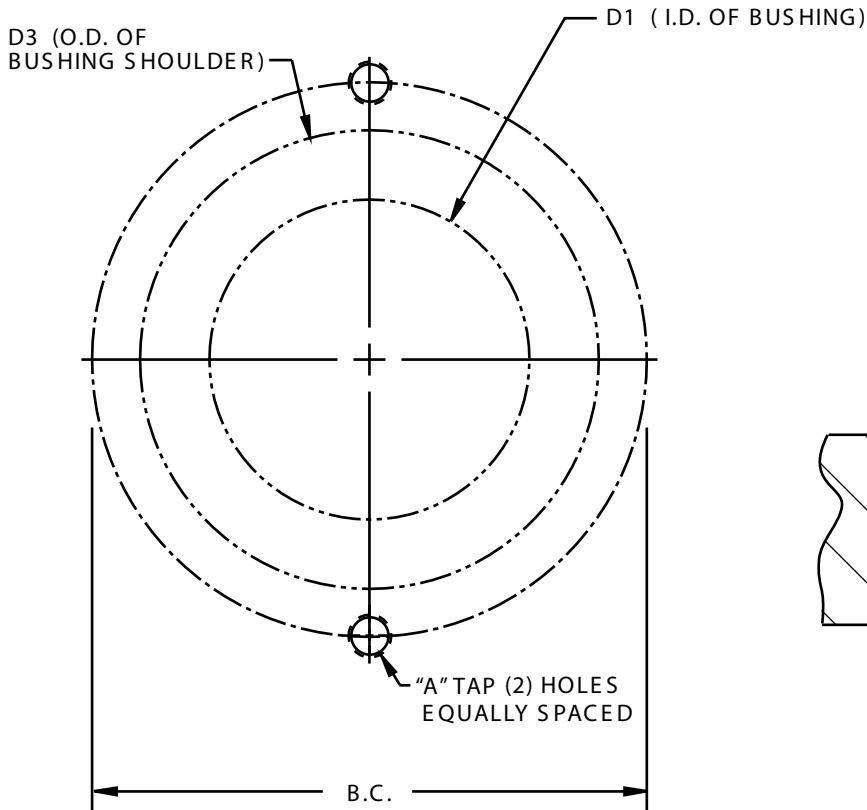

**B**

"A" = M8 x 1.25 (USE 1 CLAMP PER BUSHING)

D1	D3	B.C. (D3+18)
32	50	68
40	63	81
50	71	89
63	90	108
80	112	130
100	140	158
115	155	173

"A" = M10 x 1.25 (USE 2 CLAMPS PER BUSHING)

D1	D3	B.C. (D3+21)
32	50	71
40	63	84
50	71	92
63	90	111
80	112	133
100	140	161
115	155	176
125	180	201

## NOTES & SPECIFICATIONS:

- Order bushing clamps separately.
- Screws must engage 16 mm minimum deep into die shoe for M8 screws and 20mm minimum for M10 screws.
- Each clamp must withstand 10,000 newtons pull.
- Bushing clamp styles vary per OEM user.

**C**  
**A**

# FINGER GAGE

(G81 SERIES)

GLOBAL STANDARD COMPONENTS

TM **NAAMS**



Stamping

05/19/00

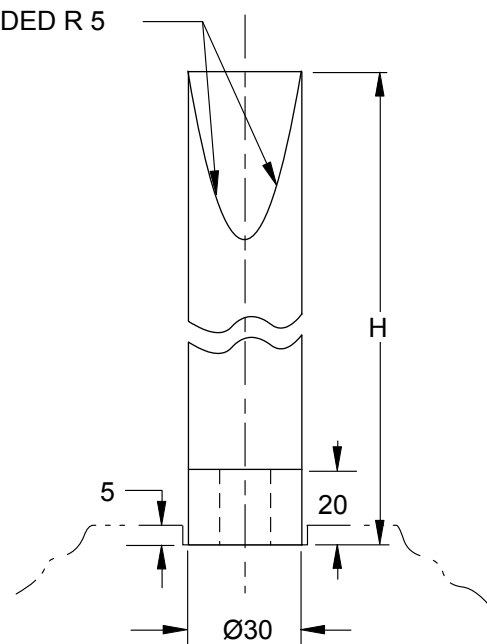
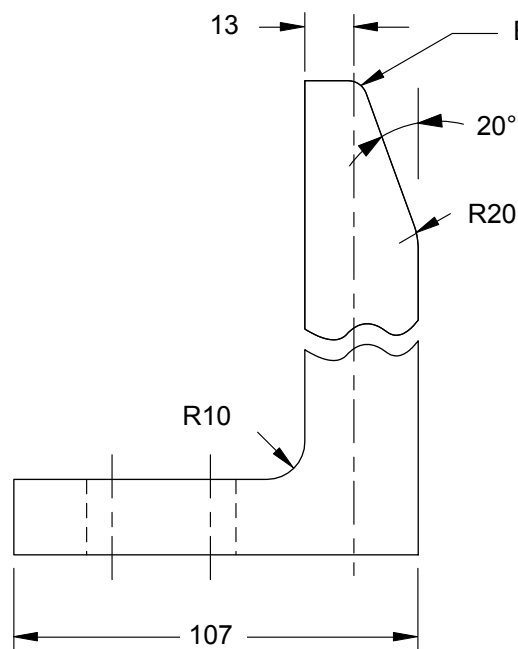
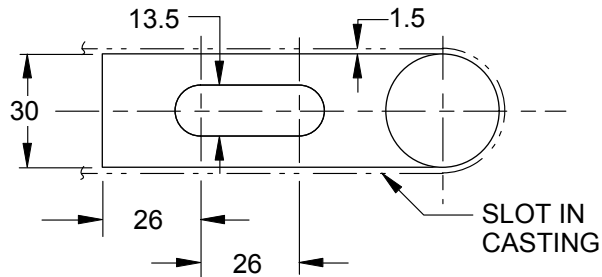

## NOTES & SPECIFICATIONS:

Material, steel

NAAMS CODE	H
G813006	65
G813009	90
G813012	120
G813015	150
G813018	180
G813025	250

A

# BALANCING CONES

(G91 SERIES)

GLOBAL STANDARD COMPONENTS

# NAAMS



Stamping

05/19/00

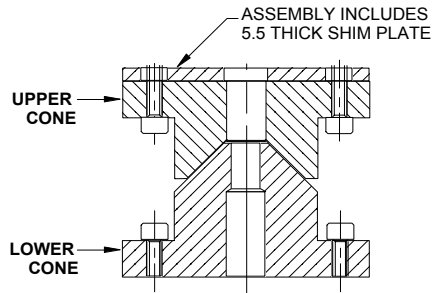

LOWER  
CONE

UPPER  
CONE

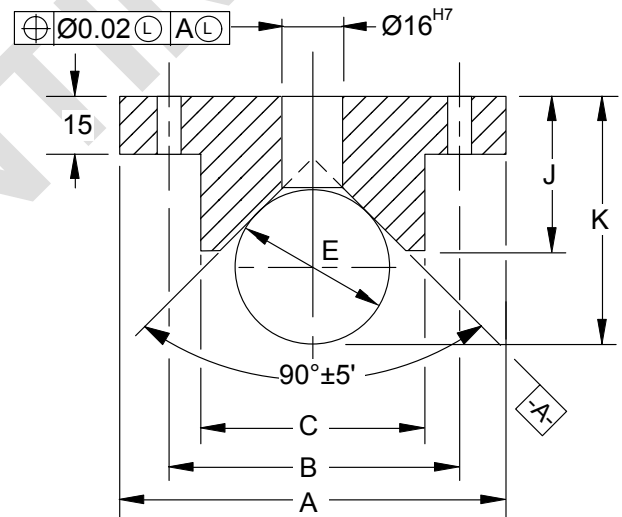
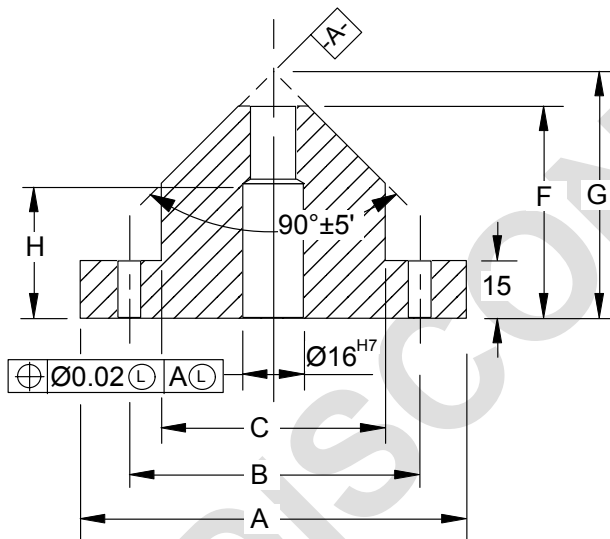
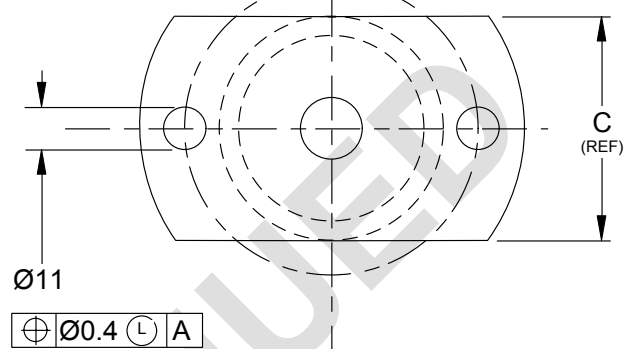
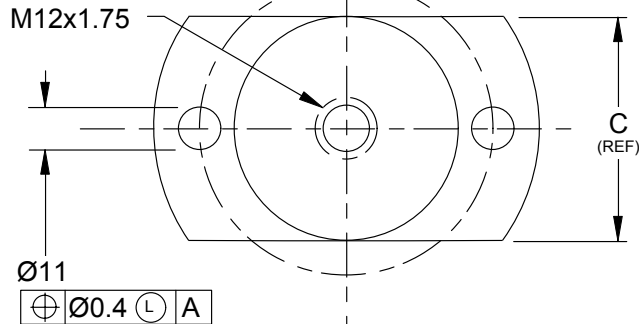

CODING ON FOLLOWING PAGE

## NOTES & SPECIFICATIONS:

Material: steel, case harden to Rc 60-64

B

A

# BALANCING CONES

(G91 SERIES)

GLOBAL STANDARD COMPONENTS

TM **NAAMS**



Stamping

05/19/00

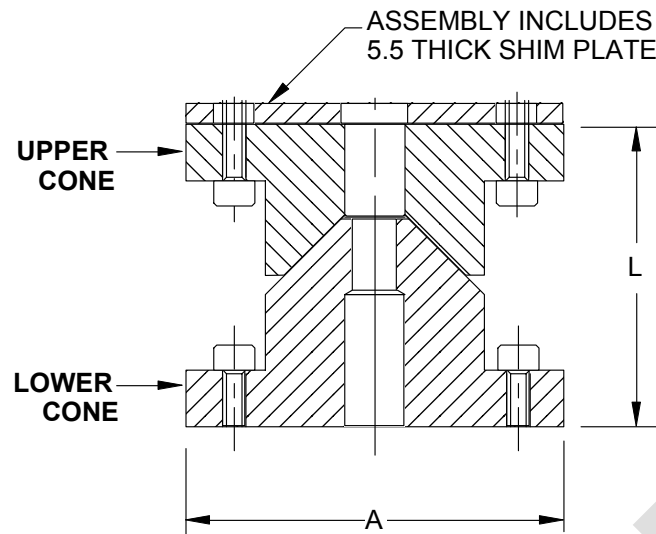

A	CONE	B	C	E	F	G	H	J	K	L	CONTACT SURFACE
100	LOWER	76	58	--	55	64	35	--	--	80	1555 mm <sup>2</sup>
	UPPER			40	--	--	40	64.28			
120	LOWER	96	78	--	65	74	45	--	--	90	3377 mm <sup>2</sup>
	UPPER			50	--	--	50	76.36			

NAAMS CODE*	A	L
G911008	100	80
G911209	120	90

\* Assembly consisting of 1 shim plate,  
1 upper cone and, 1 lower cone

# DISAPPEARING GAGE

(G82 SERIES)

GLOBAL STANDARD COMPONENTS



Stamping

10/19/01

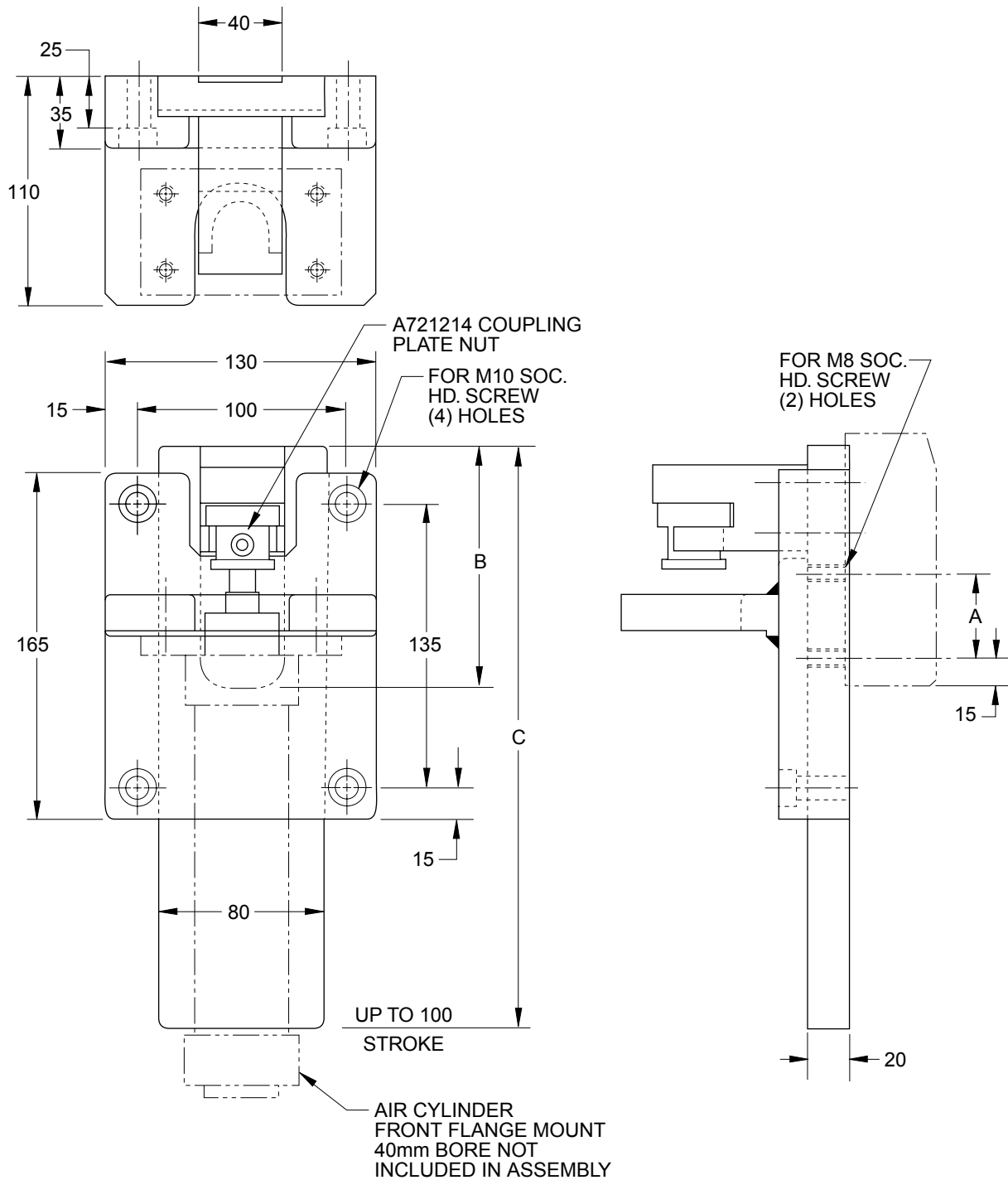

NAAMS CODE	SLIDE TRAVEL	A	B	C
G820100	UP TO 100	40	115	275
G820160	125 AND 160	90	165	335
G820200	200	140	215	375
G820250	250	190	265	425

# 175 mm WIDE U & V BLOCKS

( G34 SERIES)

Stamping

04/14/15

## FEMALE "U" BLOCK

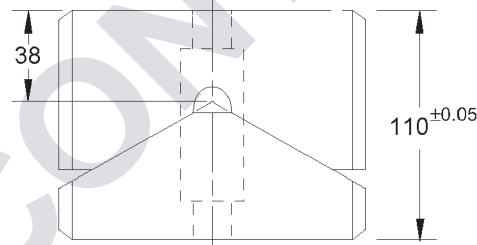
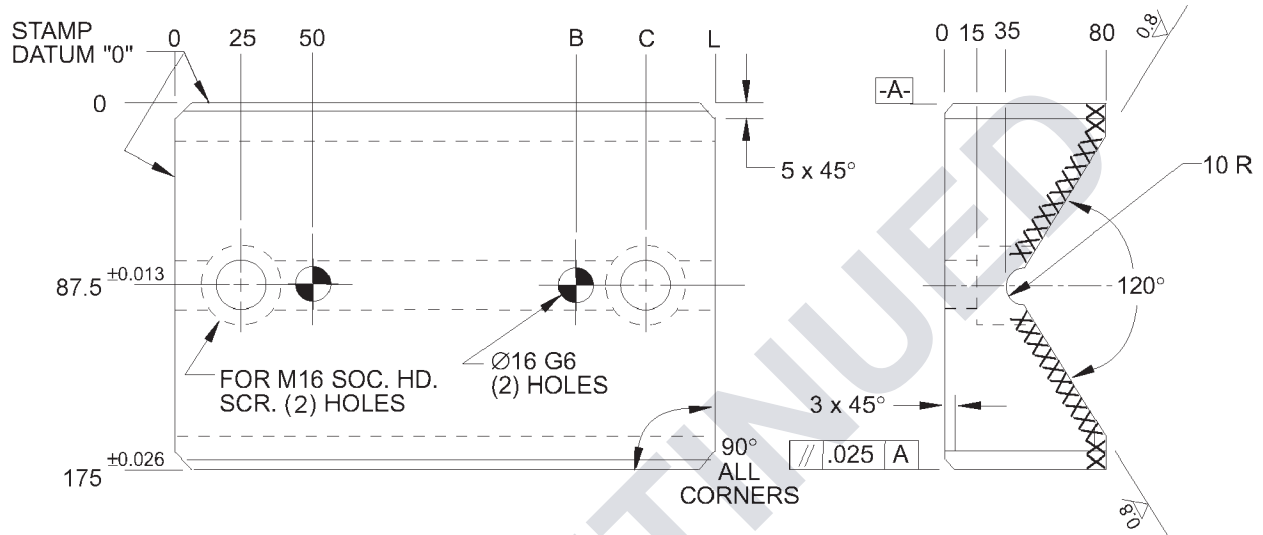

"U" & "V" BLOCK ASSEMBLY

FEMALE "U" BLOCK			
NAAMS CODE	L	B	C
G341715	150	100	125
G341720	200	150	175

### NOTES & SPECIFICATIONS:

Material, steel

Surface harden cross-hatched areas.

Tolerance between screw holes  $\pm 0.12$

Tolerance between dowel holes  $\pm 0.10$

<sup>1.6</sup> All over except where otherwise stated.

Break all sharp corners.

A

# 175 mm WIDE U & V BLOCKS

( G35 & G36 SERIES)

Stamping

04/14/15

## MALE "V" BLOCK

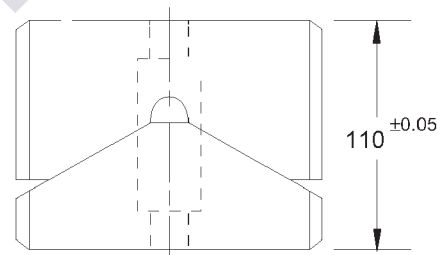
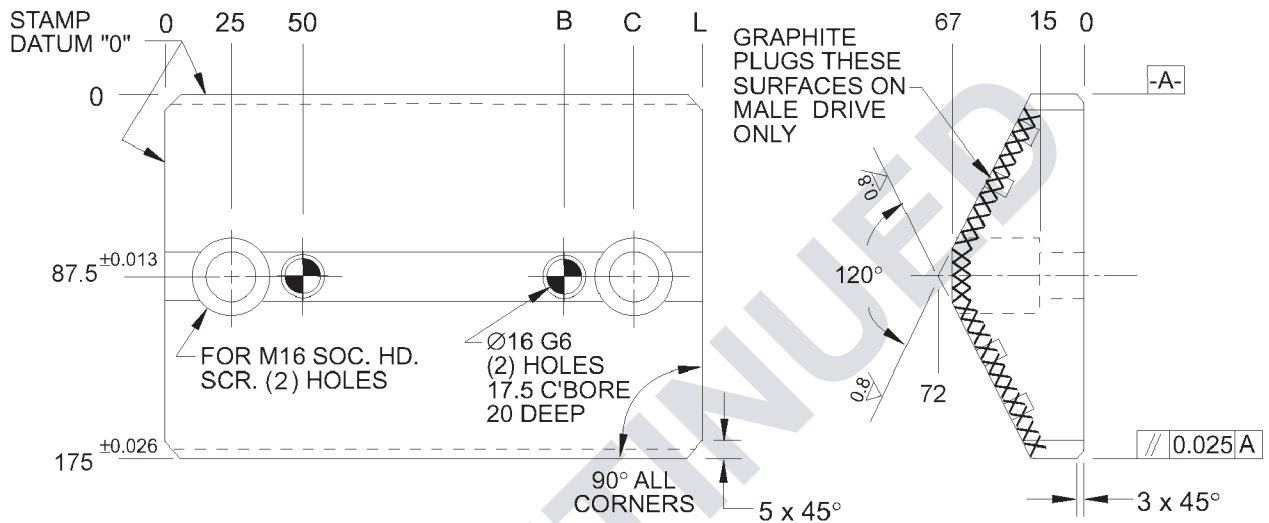

"U" & "V" BLOCK ASSEMBLY

MALE "V" BLOCK				
NAAMS CODE(X)	NAAMS CODE(Y)	L	B	C
G351715	G361715	150	100	125
G351720	G361720	200	150	175

### NOTES & SPECIFICATIONS:

Material, steel or bronze

Use code X for steel

Use code Y for bronze

Surface harden cross-hatched areas on steel.

Tolerance between screw holes  $\pm 0.12$

Tolerance between dowel holes  $\pm 0.10$

<sup>1.6</sup> All over except where otherwise stated.

Break all sharp corners

Male "V" driver requires evenly distributed graphite plugs to cover 20–30% of the surface that requires lubrication

**A**



**Blank Page**

**A**

**Data Removed.  
Pages Left Blank For Future Use.**

**Blank Page**

**B**

**A**

**Data Removed.  
Pages Left Blank For Future Use.**

**Blank Page**

**A**

**Data Removed.  
Pages Left Blank For Future Use.**

**Blank Page**

**B**

**Data Removed.  
Pages Left Blank For Future Use.**

**A**

**Blank Page**

A

B

**Data Removed.  
Pages Left Blank For Future Use.**

**Blank Page**

**A**

**Data Removed.  
Pages Left Blank For Future Use.**

**Blank Page**

**B**

**Data Removed.  
Pages Left Blank For Future Use.**

**A**

**Blank Page**

**Data Removed.  
Pages Left Blank For Future Use.**



**Blank Page**

**Data Removed.  
Pages Left Blank For Future Use.**



# BLANK CROWDER

(G56 SERIES)

GLOBAL STANDARD COMPONENTS



Stamping

08/01/11

NAAMS Code	A	B	H	STROKE S
G5615075	163	55	75	15
G5615100	163	55	100	15
G5615125	163	55	125	15
G5615150	163	55	150	15
G5615175	163	55	175	15
G5615200	163	55	200	15
G5630075	178	60	75	30
G5630100	178	60	100	30
G5630125	178	60	125	30
G5630150	178	60	150	30
G5630175	178	60	175	30
G5630200	178	60	200	30
G5650075	198	80	75	50
G5650100	198	80	100	50
G5650125	198	80	125	50
G5650150	198	80	150	50
G5650175	198	80	175	50
G5650200	198	80	200	50

A

**BLANK PAGE**

**Data Removed.  
Pages Left Blank For Future Use.**

**BLANK PAGE**

**Data Removed.  
Pages Left Blank For Future Use.**

# TRIM TAB PILOT GAGE

(G95 SERIES)

GLOBAL STANDARD COMPONENTS

# NAAMS



Stamping

08/01/11

DETAIL	DESCRIPTION
1	PILOT PIN GAGE
2	TRIM BLADE </td
3	GAGE BLOCK
4	PILOT GAGE BASE
5	GAGE BLOCK ADJUSTMENT SCREW

NAAMS CODE	"H" PIN HEIGHT	PIN DIAMETER	TRIM BLADE STEEL
G95150A	136	12.75	YES
G95300B	286	12.75	YES
G95150C	136	12.75	NO
G95300D	286	12.75	NO
G95150E	NO PIN	12.75	YES
G95300F	NO PIN	—	NO
G95150G	136	15.75	YES
G95300H	286	15.75	YES
G95150J	136	15.75	NO
G95150K	NO PIN	15.75	YES
G95300L	286	15.75	NO
G95150M	136	19.75	YES
G95300N	286	19.75	YES
G95150P	136	19.75	NO
G95300R	286	19.75	NO
G95150S	NO PIN	19.75	YES

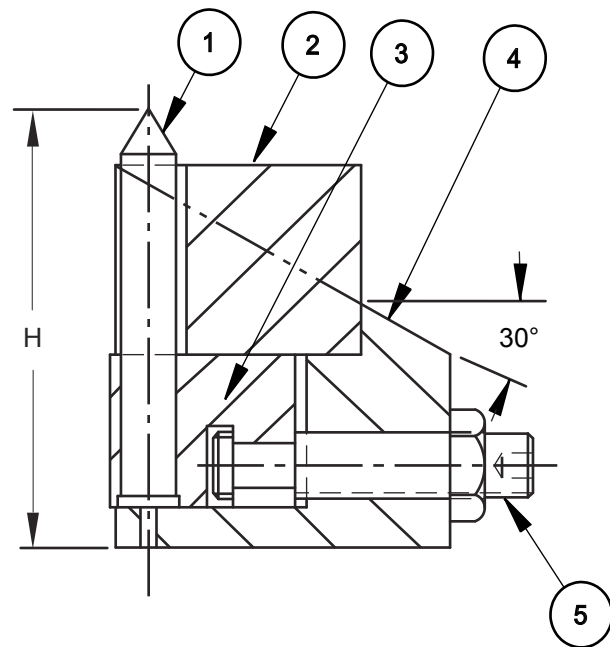
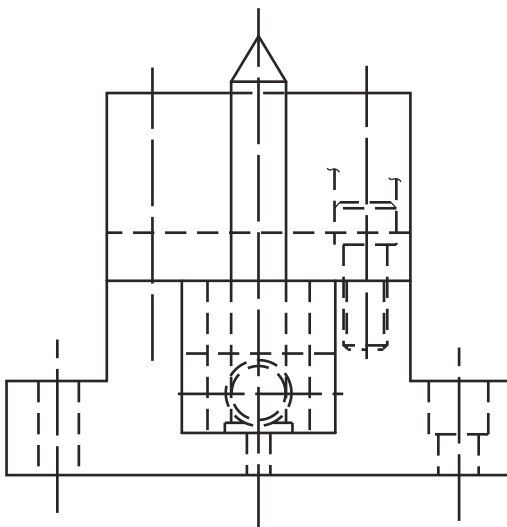
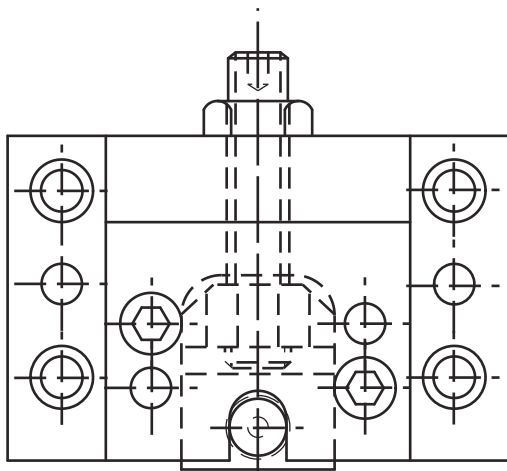

CONTINUED ON FOLLOWING PAGES

**NOTES & SPECIFICATIONS:**

MATERIAL : SEE EACH DETAIL FOR MATERIAL

# TRIM TAB PILOT GAGE

(G95 SERIES)

GLOBAL STANDARD COMPONENTS

# NAAMS



Stamping

08/01/11

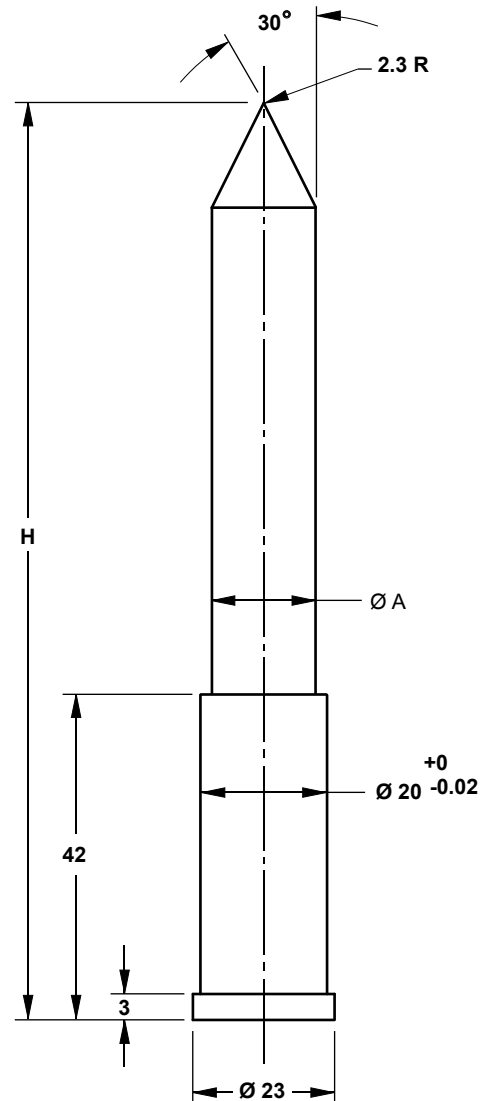

NAAMS CODE	Ø A	H
G9513136	12.75	136
G9513286	12.75	286
G9516136	15.75	136
G9516286	15.75	286
G9520136	19.75	136
G9520286	19.75	286

## 1 PILOT PIN GAGE

### NOTES & SPECIFICATIONS:

MATERIAL : ISO 4957 - 50CrMoV15-1  
HARDEN Rc 56-58 DOUBLE TEMPER

# TRIM TAB PILOT GAGE

(G95 SERIES)

GLOBAL STANDARD COMPONENTS

# NAAMS



Stamping

08/01/11

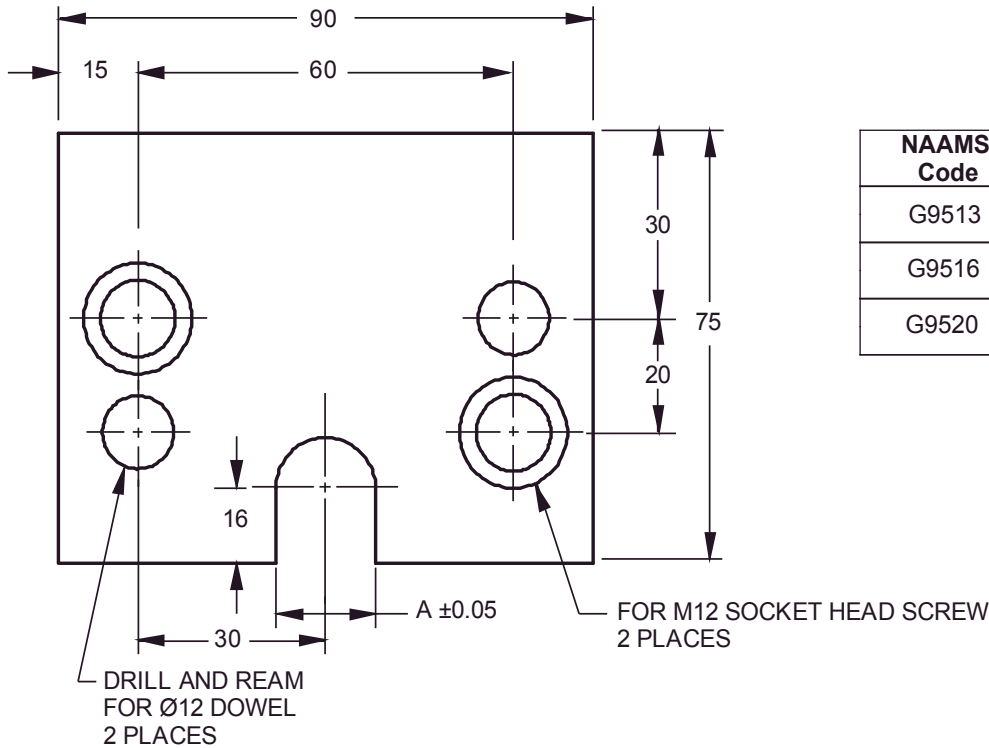

NAAMS Code	Dim. A	Pilot Required
G9513	13.0	9513136
		9513286
G9516	16.0	9516136
		9516286
G9520	20.0	9520136
		9520286

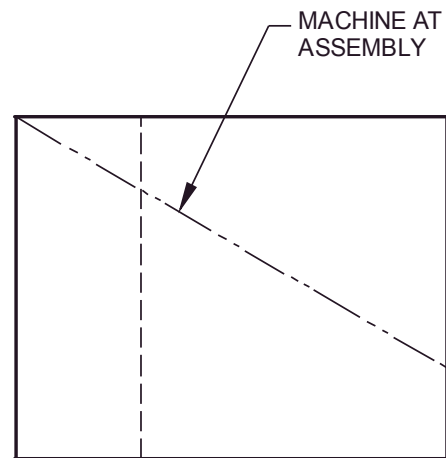
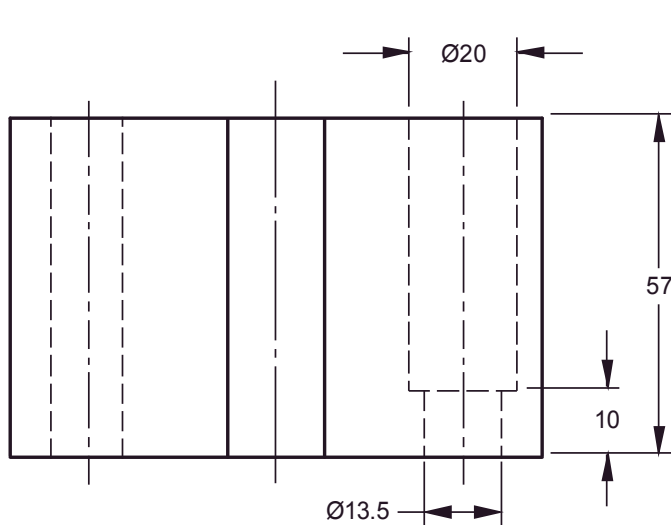

2 TRIM BLADE

**NOTES & SPECIFICATIONS:**

MATERIAL : ISO 4957 - 50CrMoV15-1 LEFT SOFT FINISH ASSEMBLY



# TRIM TAB PILOT GAGE

(G95 SERIES)

GLOBAL STANDARD COMPONENTS

# NAAMS



Stamping

08/01/11

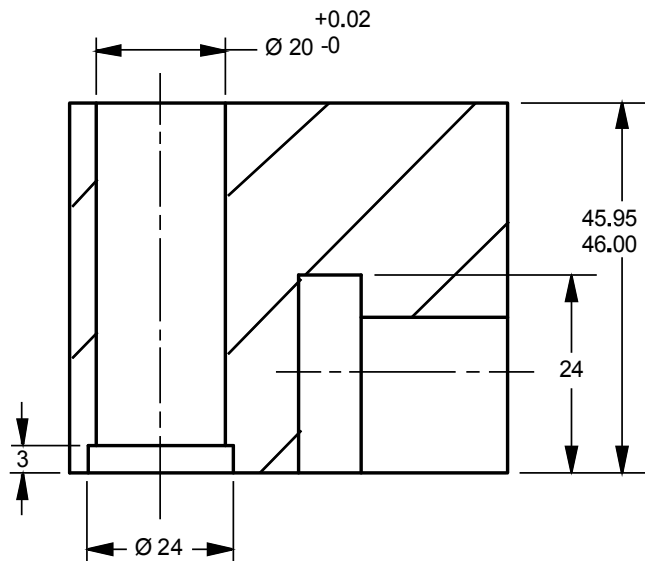
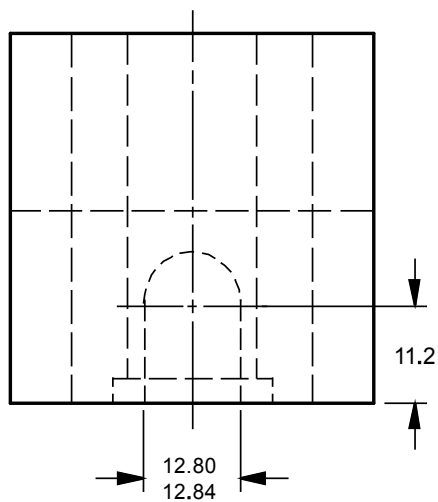
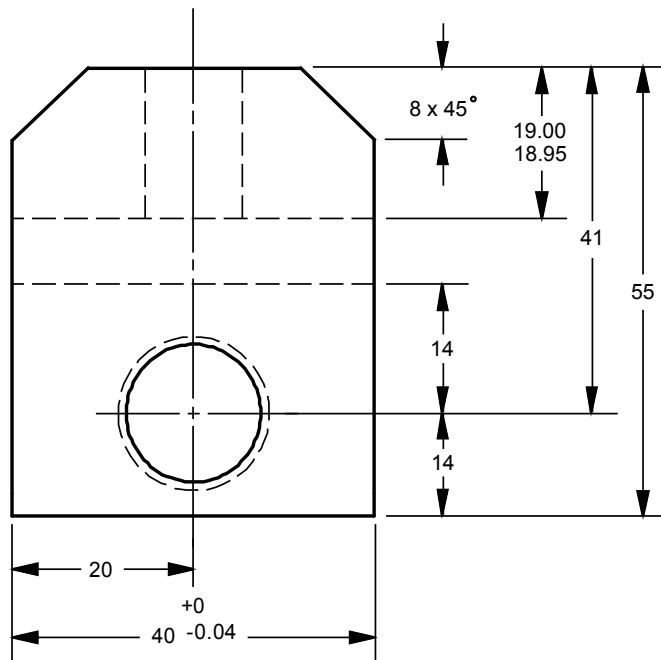

3 GAGE BLOCK

NOTES & SPECIFICATIONS:  
MATERIAL : ISO 683/18 - C20

# TRIM TAB PILOT GAGE

(G95 SERIES)

GLOBAL STANDARD COMPONENTS

# NAAMS



Stamping

08/01/11

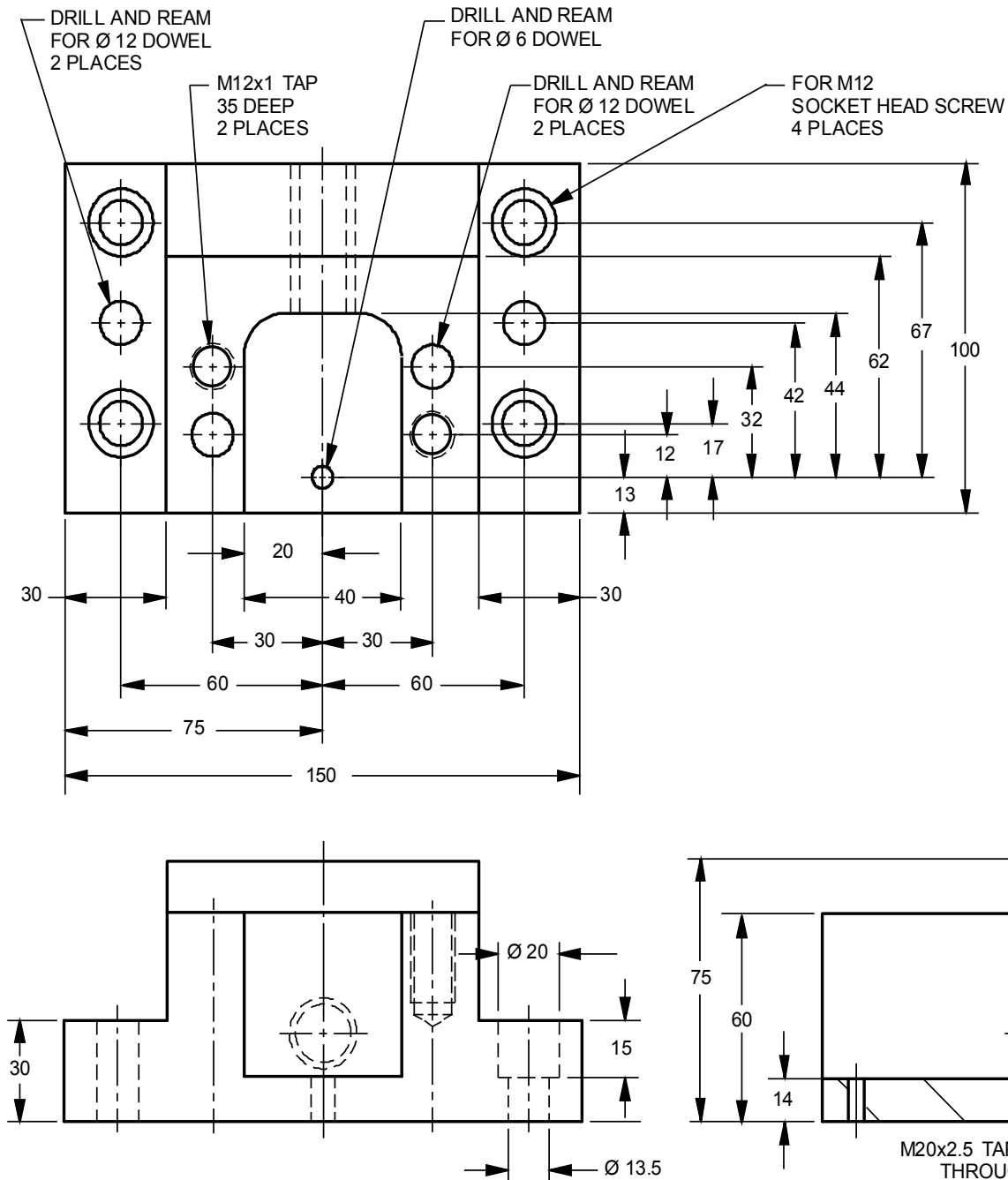

4 PILOT GAGE BASE

**NOTES & SPECIFICATIONS:**  
 MATERIAL : ISO 683/18 - C20

# TRIM TAB PILOT GAGE

(G95 SERIES)

GLOBAL STANDARD COMPONENTS

# NAAMS



Stamping

08/01/11

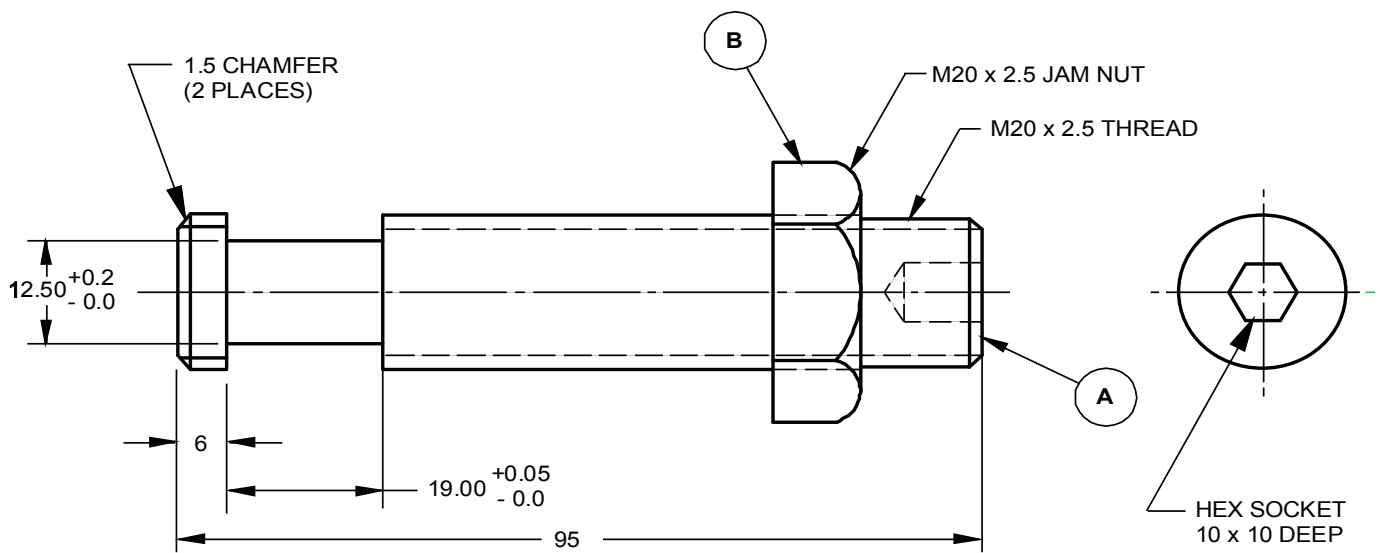

5 GAGE BLOCK ADJUSTMENT SCREW

#### NOTES & SPECIFICATIONS:

MATERIAL : A. ISO 683/18 - C18 - B7 THREADED ROD -OR- ISO 848-1 (min)

B. ISO 683/18 - C20

# 200MM ADJUSTABLE BLANK GAGE WITH BAR SENSOR G96 SERIES

GLOBAL STANDARD COMPONENTS



Stamping

12/19/12

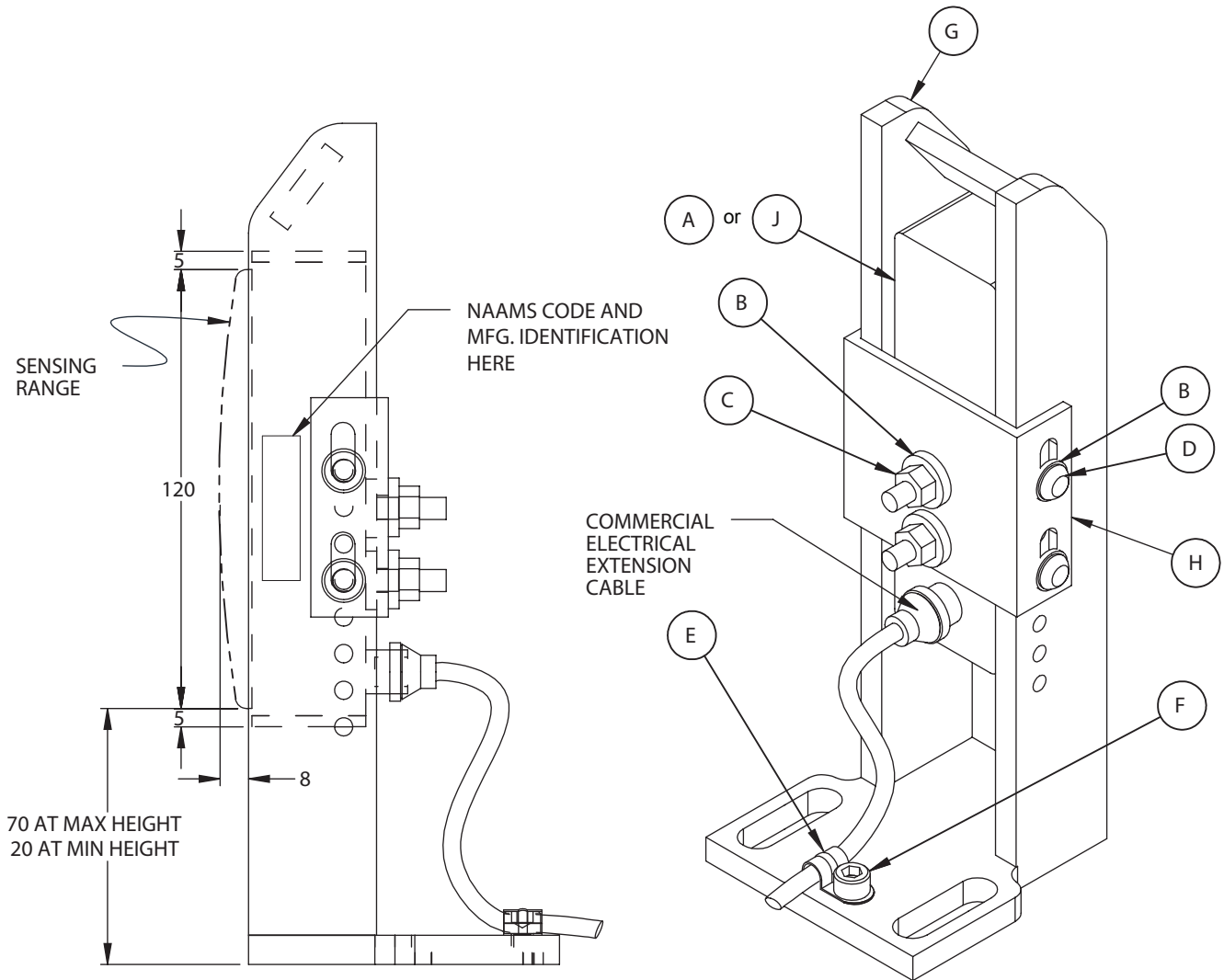

NAAMS Code - G960001 - 24VDC Sensor  
NAAMS Code - G960002 - 120VAC Sensor

NAAMS CODE			DESCRIPTION OF ADJUSTABLE BLANK GAGE WITH BAR SENSOR KIT
G960001	G960002		
ITEM I.D.	QUANTITY		
A	1	-	BAR SENSOR - 24VDC TURCK #BI20-CK40130-VP4X2-H1141/S1009 OR EQUIVALENT
B	8	8	M6 FLATWASHER
C	2	2	M6 x 0.8 LOCKNUT WITH NYLON INSERT
D	4	4	M6 x 0.8 x 12 BUTTON HEAD CAP SCREW (BLUE)
E	1	1	GENERIC M6 NYLON TUBING CLIP
F	1	1	M6 x 0.8 x 8 LONG SOCKET HEAD CAP SCREW
G	1	1	GAGE RISER BRACKET
H	1	1	SENSOR MOUNT BRACKET
J	-	1	BAR SENSOR - 120VAC TURCK #BI20-CK40130-ADZ30X2-B1131/S1009 OR EQUIVALENT

**NOTES & SPECIFICATIONS:**

- Adjustable 200mm blank gage with 130mm bar sensor.
- Mark with NAAMS code in 6mm high letters as shown, and manufacturers identification.
- Install with M10 x 30 long socket head cap screws, M10 flat washers and lock washer. (Not supplied.)
- Tack weld washers to base after final adjustment.
- For flat binders, Bottom of sensor must be 5mm below edge of nested blank.

# 200MM ADJUSTABLE BLANK GAGE WITH BAR SENSOR G96 SERIES

GLOBAL STANDARD COMPONENTS



Stamping

12/19/12

## DETAIL G GAGE RISER BRACKET G960001 or G960002

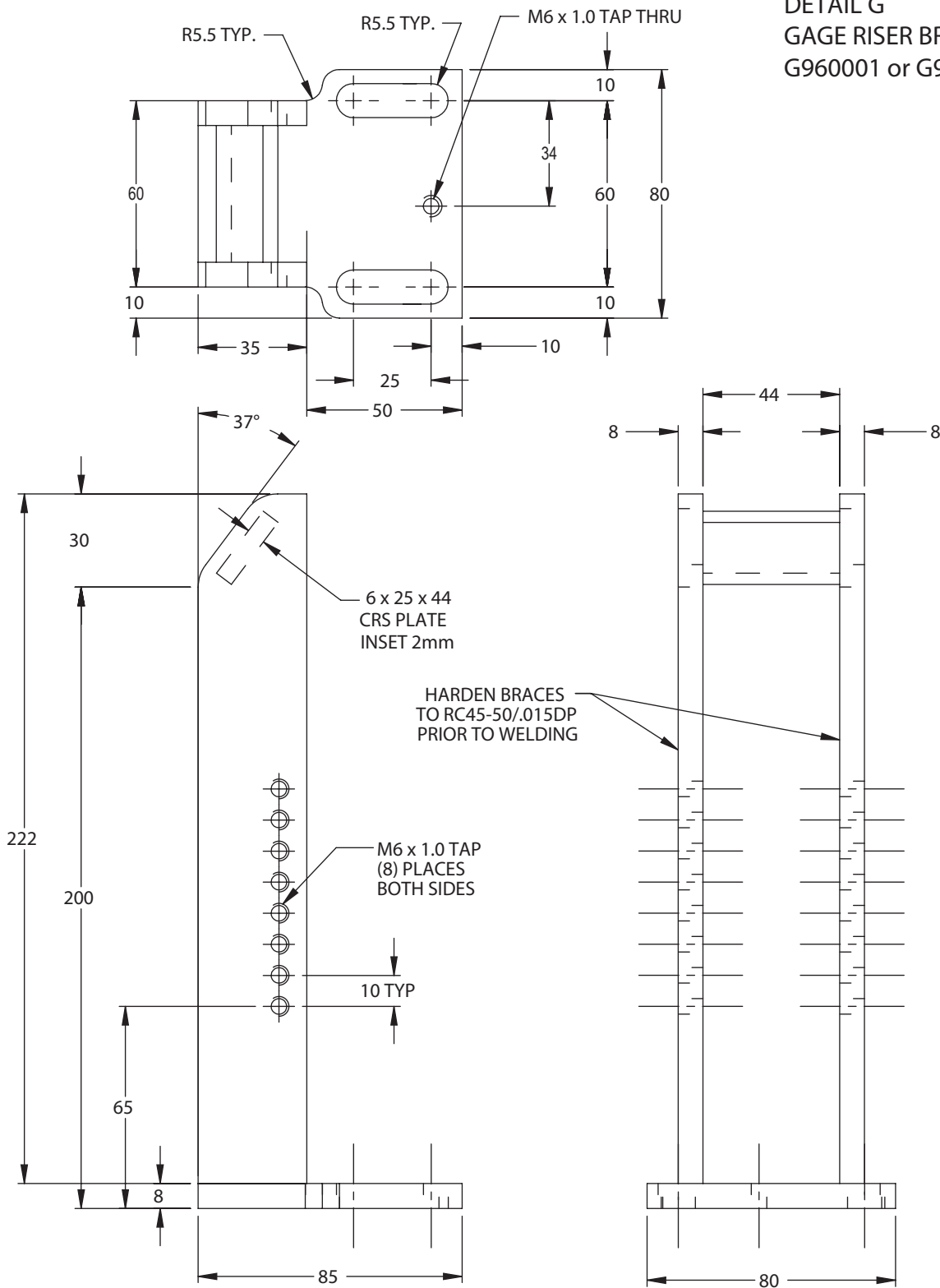

**NOTES & SPECIFICATIONS:**  
MATERIAL: ISO 683/18 - C20 (BLACK OXIDE FINISH)

# 200MM ADJUSTABLE BLANK GAGE WITH BAR SENSOR G96 SERIES

GLOBAL STANDARD COMPONENTS



Stamping

12/19/12

DETAIL H  
SENSOR MOUNT BRACKET  
G960001 or G960002

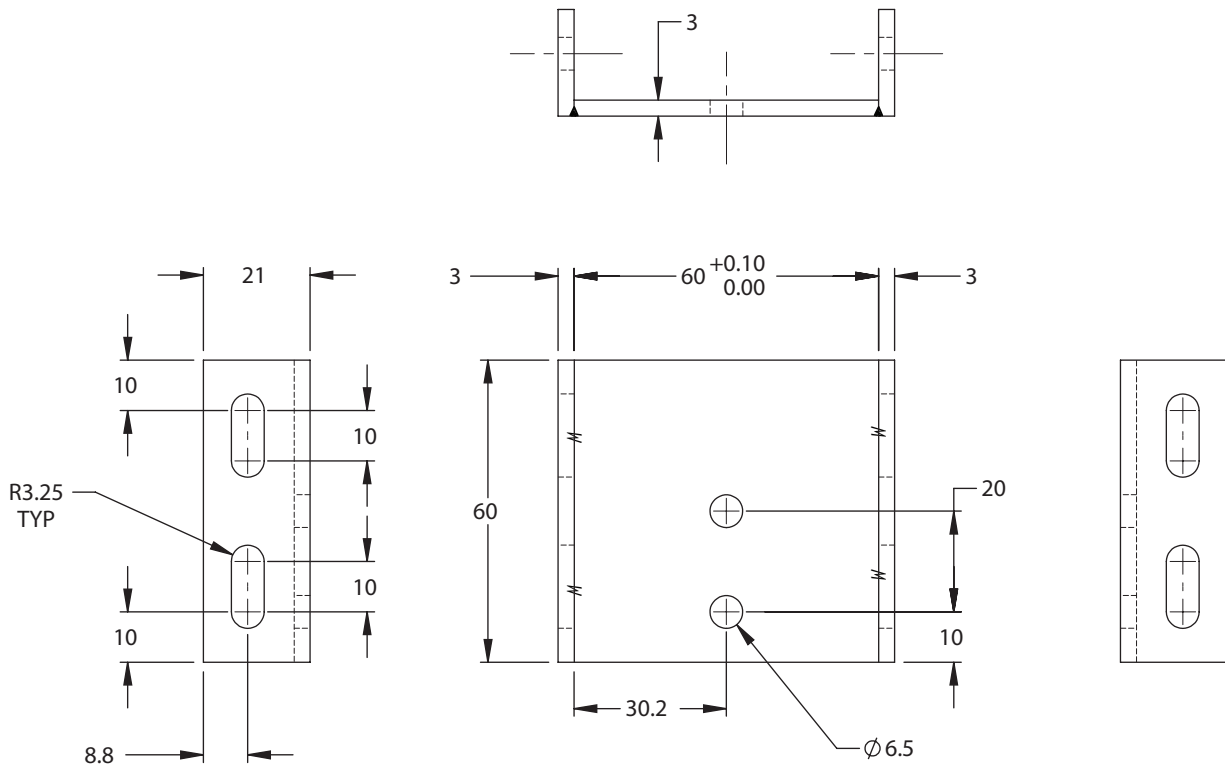

## NOTES & SPECIFICATIONS:

Material: ISO 683/18 - C20 (Black Oxide Finish)



# 65 mm WIDE U BLOCK

(G98 SERIES)

GLOBAL STANDARD COMPONENTS



Stamping

04/23/14

## FEMALE "U" BLOCK

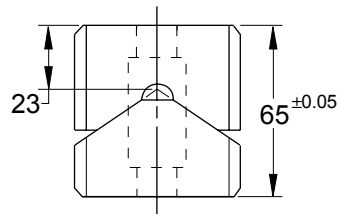
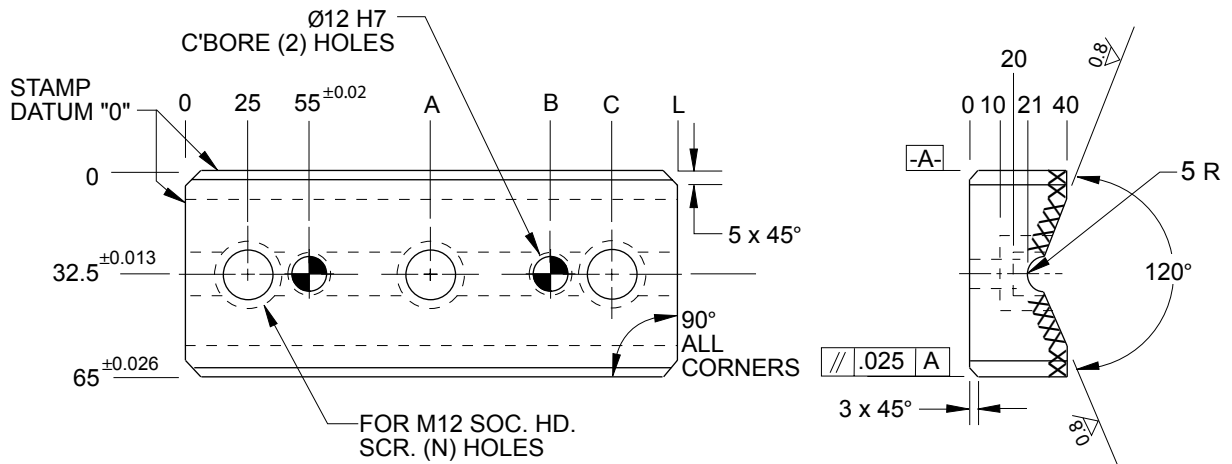

TYPICAL SECTION  
"U" & "V" BLOCK ASSEMBLY

FEMALE "U" BLOCK					
NAAMS CODE	L	A	B	C	N
G987515	150	—	100	125	2
G987520	200	—	150	175	2
G987525	250	125	200	225	3
G987530	300	150	250	275	3

### NOTES & SPECIFICATIONS:

Material, ISO 683/1 42CrMo4

Surface harden cross-hatched areas.

Tolerance between screw holes  $\pm 0.12$

Tolerance between dowel holes  $\pm 0.10$

<sup>1.6</sup> All over except where otherwise stated.

Break all sharp corners.

A



# 125 mm WIDE V BLOCK

(G99 SERIES)

GLOBAL STANDARD COMPONENTS



Stamping

04/23/14

## MALE "V" BLOCK

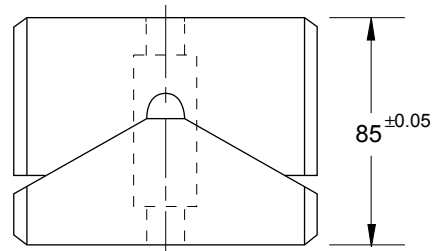
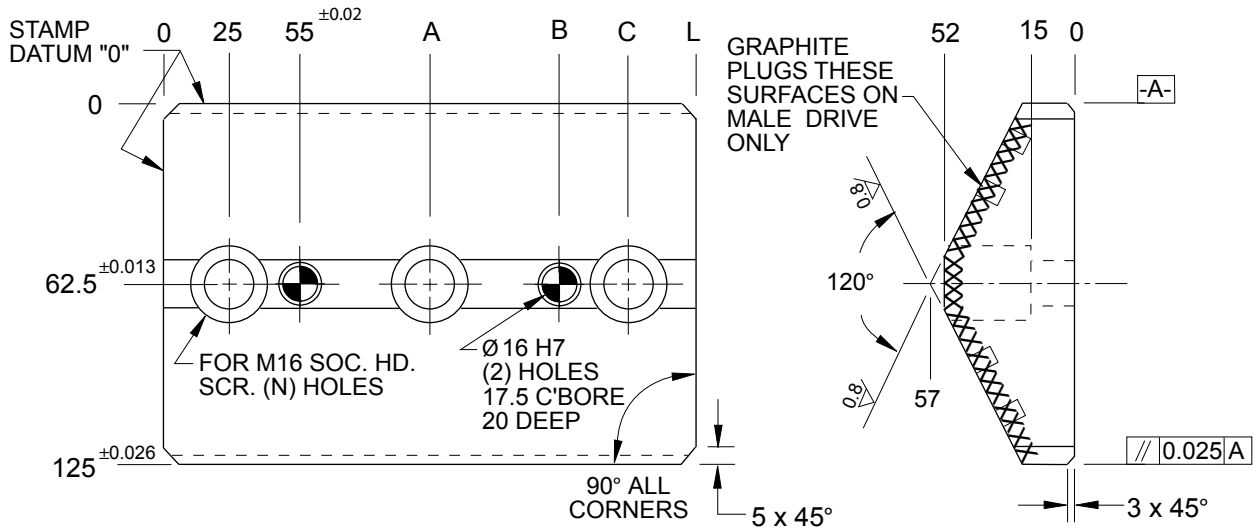

"U" & "V" BLOCK ASSEMBLY

MALE "V" BLOCK					
NAAMS CODE	L -0.1 -0.3	A ±0.2	B ±0.2	C ±0.2	N
G1001215	150	-	100	125	2
G1001220	200	-	150	175	2
G1001225	250	125	200	225	3
G1001230	300	150	250	275	3

### NOTES & SPECIFICATIONS:

Material, ISO-CuZn25Al5

Tolerance between screw holes  $\pm 0.12$

Tolerance between dowel holes  $\pm 0.10$

<sup>1.6</sup> All over except where otherwise stated.

Break all sharp corners

Male "V" driver requires evenly distributed graphite plugs to cover 20–30% of the surface that requires lubrication

A

# 125 mm WIDE U BLOCK

(G100 SERIES)

Stamping

04/23/14

## FEMALE "U" BLOCK

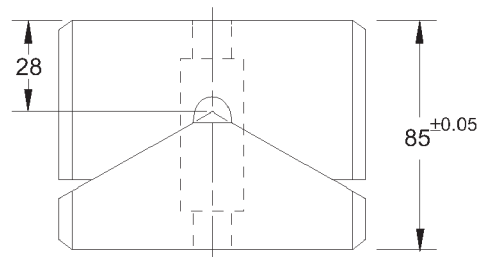
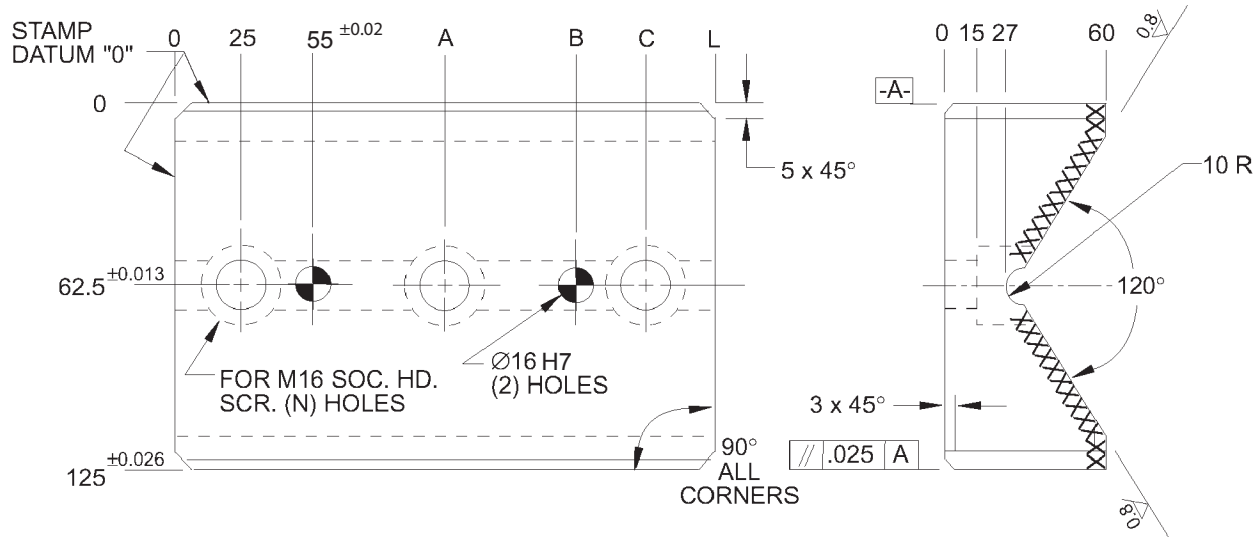

"U" & "V" BLOCK ASSEMBLY

FEMALE "U" BLOCK					
NAAMS CODE	L -0.1 -0.3	A ±0.2	B ±0.2	C ±0.2	N
G991215	150	-	100	125	2
G991220	200	-	150	175	2
G991225	250	125	200	225	3
G991230	300	150	250	275	3

### NOTES & SPECIFICATIONS:

Material, ISO 683/1 42CrMo4

Surface harden cross-hatched areas.

Tolerance between screw holes ±0.12

Tolerance between dowel holes ±0.10

1.6 All over except where otherwise stated.

Break all sharp corners.

A

# GUIDE PIN BUSHING TOE CLAMPS

(G101 & G102 SERIES)

GLOBAL STANDARD COMPONENTS



Stamping

06/13/17

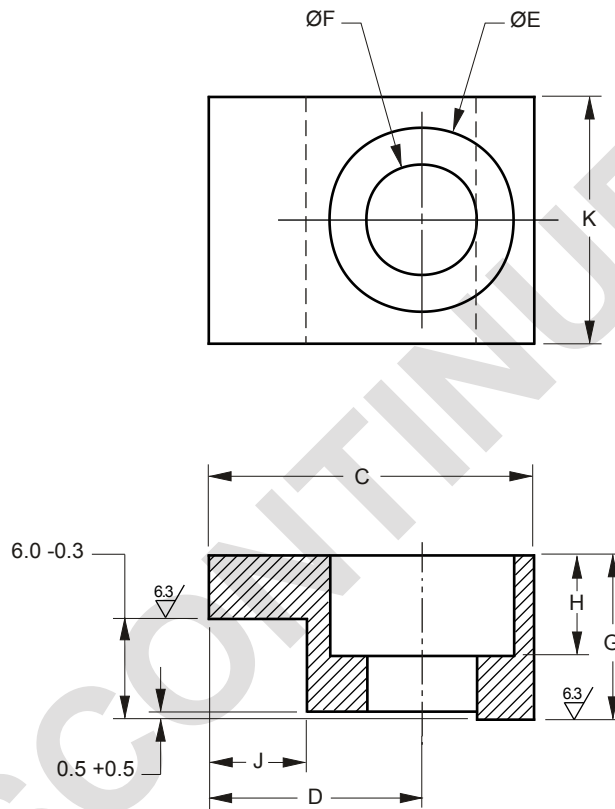

NAAMS CODE	BUSHING I.D.	C h9	D	E +0.2	F +0.2	G +0.2	H +0.2	J +0.3	K +0.3	CLAMPS REQUIRED
G1012520	25	25	15	15	9	12	8.5	5	20	1
	32									
	40									
	50									
G1023225	63	32	21	18	11.5	16	11.5	10	25	2
	80									
	100									
	125									

## NOTES & SPECIFICATIONS:

Material: steel.  
Break all sharp edges.  
Mark with NAAMS Code and manufacturers identification.  
Each clamp must withstand 10,000 newtons pull.

A

# BALANCING CONES

(G103 SERIES)

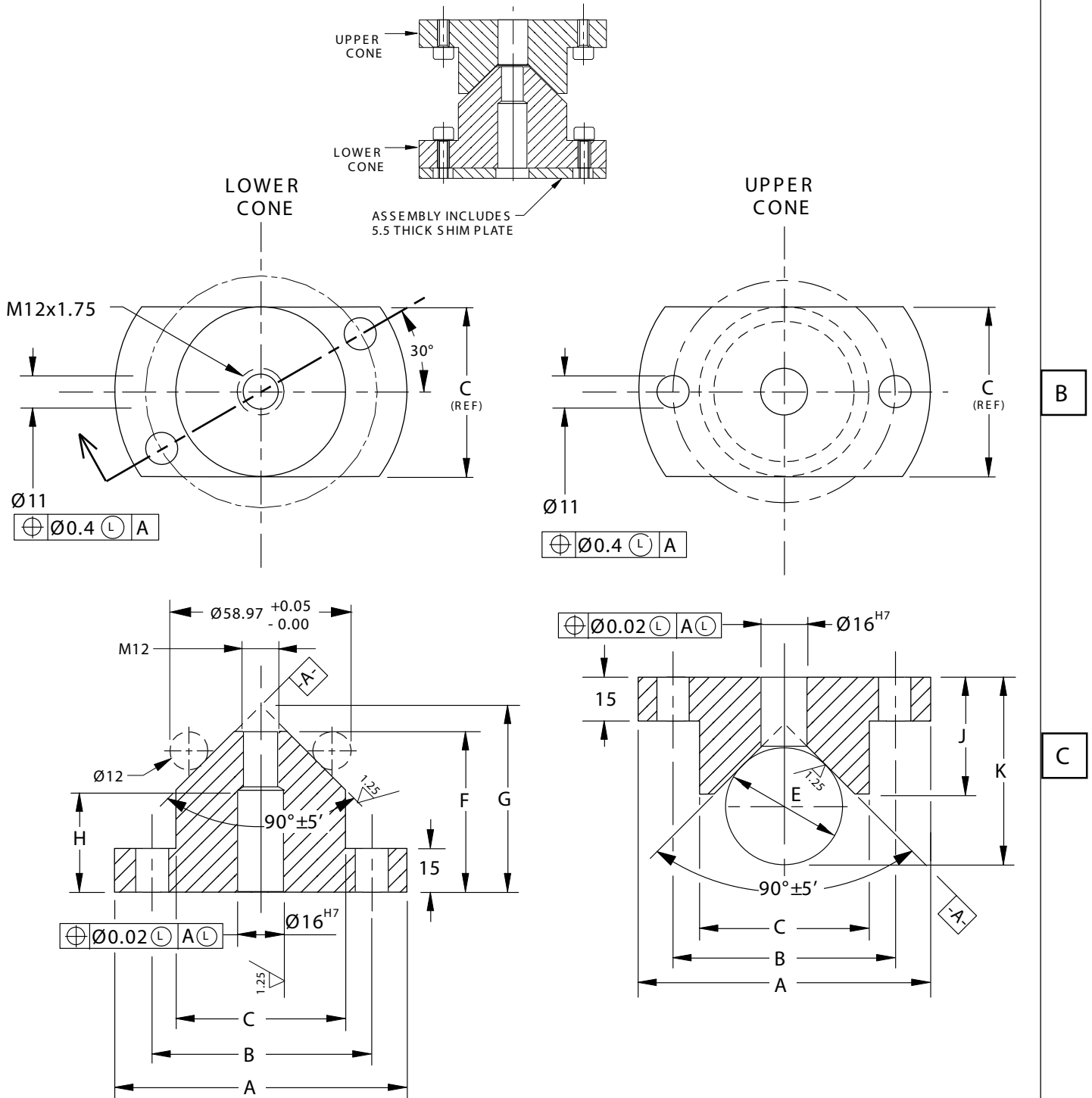

CODING ON FOLLOWING PAGE

**NOTES & SPECIFICATIONS:**

Material: steel, case harden to Rc 60-64

# BALANCING CONE SHIM & CODING

(G103 SERIES)

GLOBAL STANDARD COMPONENTS



Stamping

04/14/15

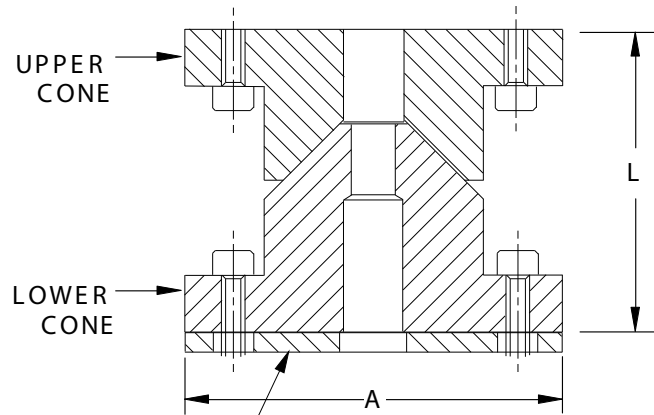

ASSEMBLY INCLUDES 5.5 THICK SHIM PLATE (ORDERED AS 6.0 THICK)

A	CONE	B	C	E	F	G	H	J	K	L	CONTACT SURFACE
100	LOWER	76	58	--	55	64	35	--	--	80	1555 mm <sup>2</sup>
	UPPER			40	--	--	--	40	64.28		
120	LOWER	96	78	--	65	74	45	--	--	90	3377 mm <sup>2</sup>
	UPPER			50	--	--	--	50	76.36		

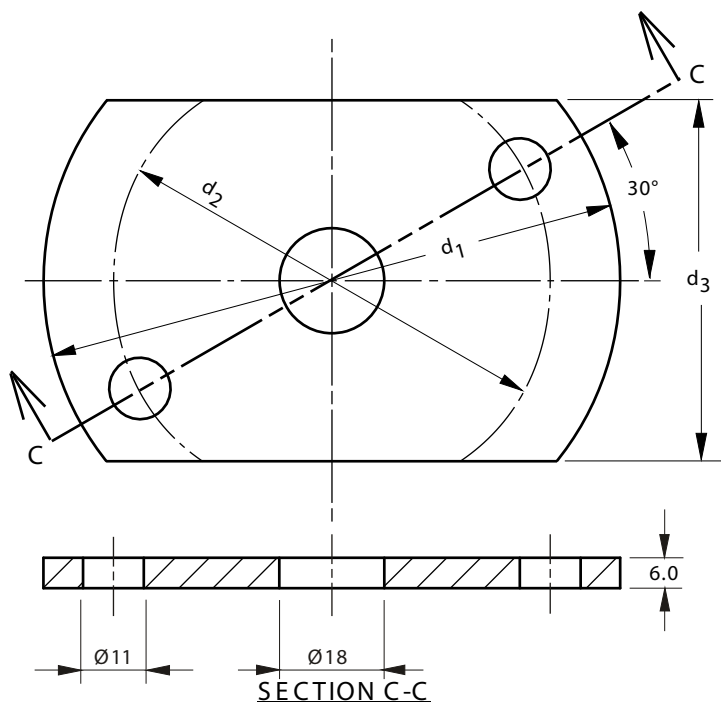

NAAMS CODE*	A	L
G1031008	100	80
G1031209	120	90

\* Assembly consisting of  
1 shim plate,  
1 upper cone and,  
1 lower cone

d1	d2	d3
105	76	58
125	96	78

**NOTES & SPECIFICATIONS:**

Solid model library part is 5.5 mm thick. Actual component to be purchased at 6.0 mm thickness. (For sizing at tryout.)

B

A

# Ø50 HD GUIDE KEEPER

(G104 Series)

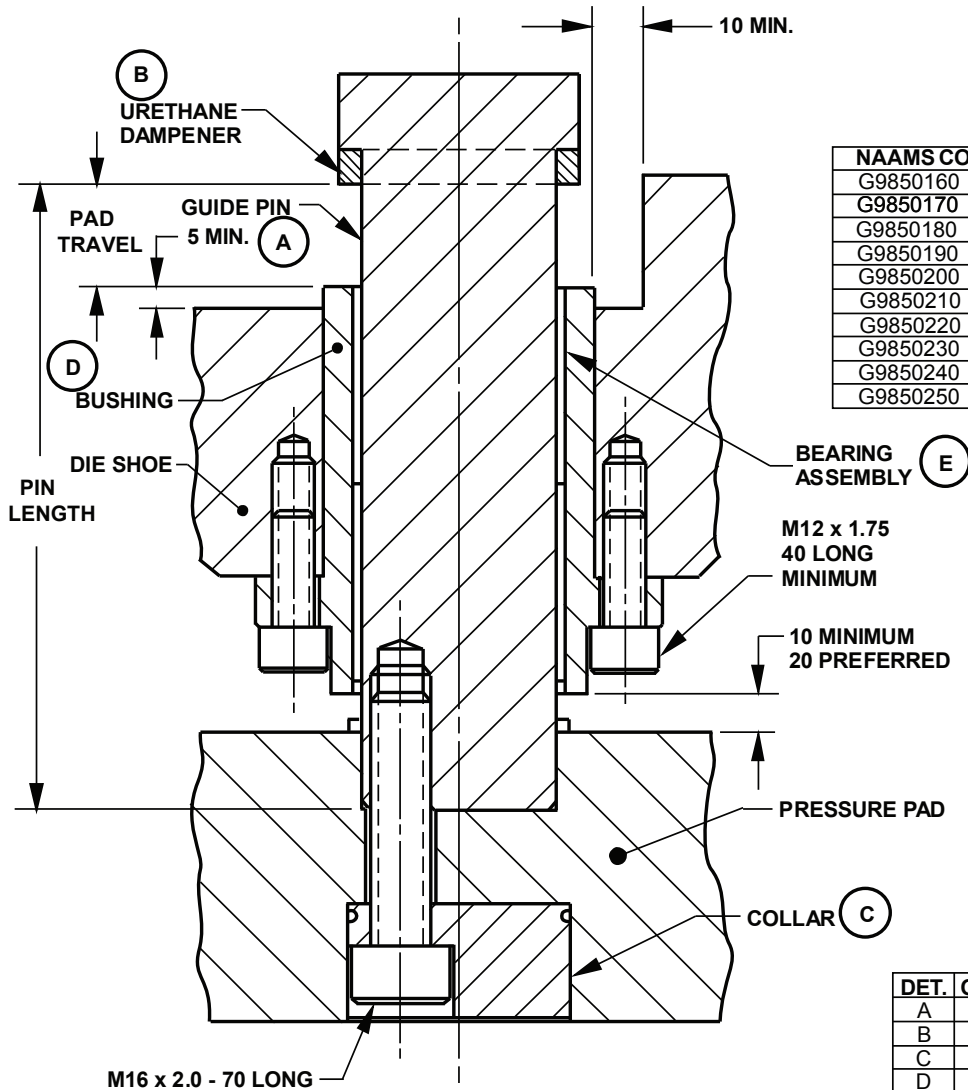

NAAMS CODE	PIN LENGTH	PAD TRAVEL
G9850160	160	25
G9850170	170	35
G9850180	180	45
G9850190	190	55
G9850200	200	65
G9850210	210	75
G9850220	220	85
G9850230	230	95
G9850240	240	105
G9850250	250	115

DET.	QUAN.	DESCRIPTION
A	1	GUIDE PIN
B	1	URETHANE DAMPENER
C	1	COLLAR
D	1	BUSHING
E	1	BEARING ASSEMBLY

## NOTES & SPECIFICATIONS:

MATERIAL: STEEL - MANUFACTURERS CHOICE

- Break all edges.
- Mark with NAAMS order code and manufacturer's logo.
- Refer to manufactures catalog for design information.
- For use in upper and lower pads.

# Ø50 HD GUIDE KEEPER

(G104 Series)

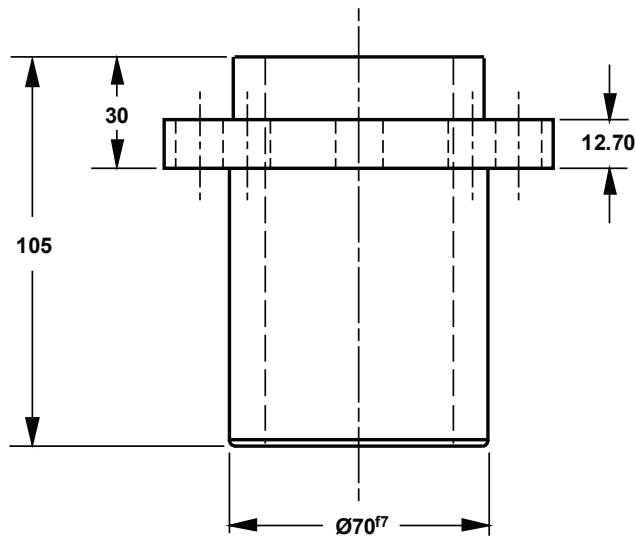
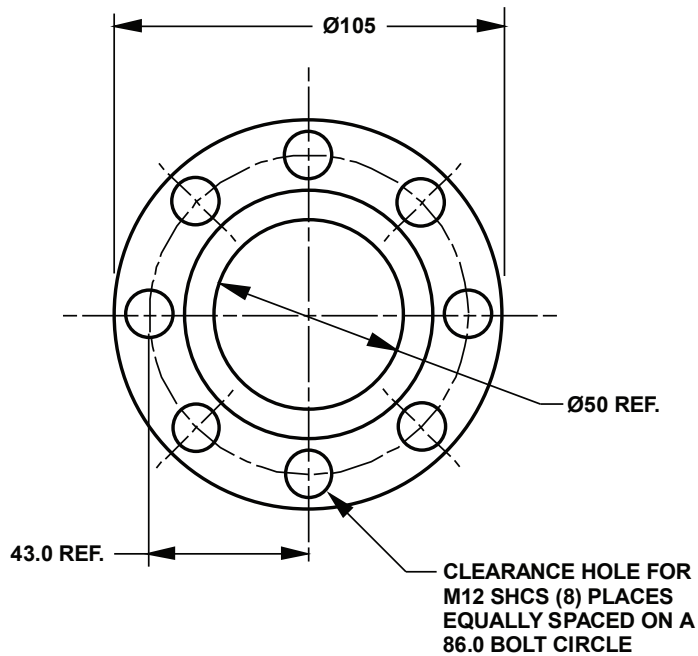

DETAIL D - BUSHING

**MATERIAL: STEEL (MANUFACTURERS CHOICE)**

- 8 - M12 x 1.75 x 40 long grade 12.9 socket head cap screws required for assembly (not supplied).

# Ø50 HD GUIDE KEEPER

(G104 Series)

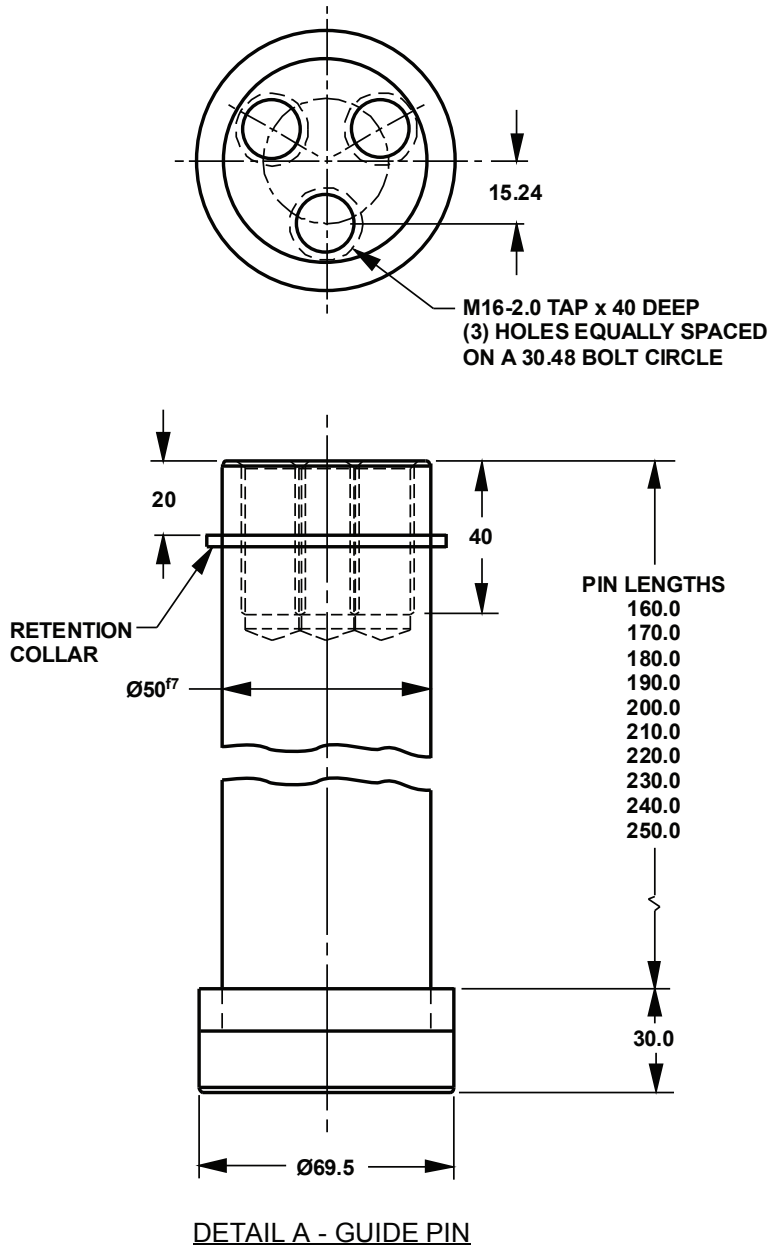

**MATERIAL: STEEL (MANUFACTURERS CHOICE)**

- For a 75mm thick steel pad, 3 - M16 x 2.0 x 70 long grade 12.9 socket head cap screws required for assembly (not supplied).



# Ø50 HD GUIDE KEEPER

(G104 Series)

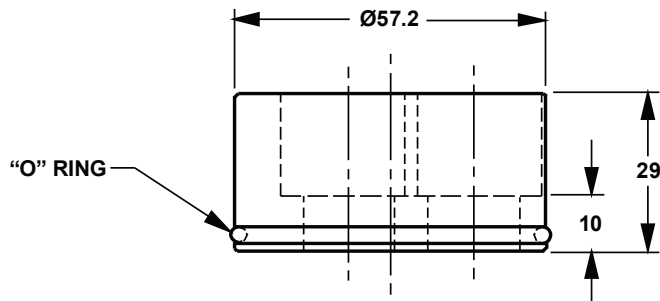
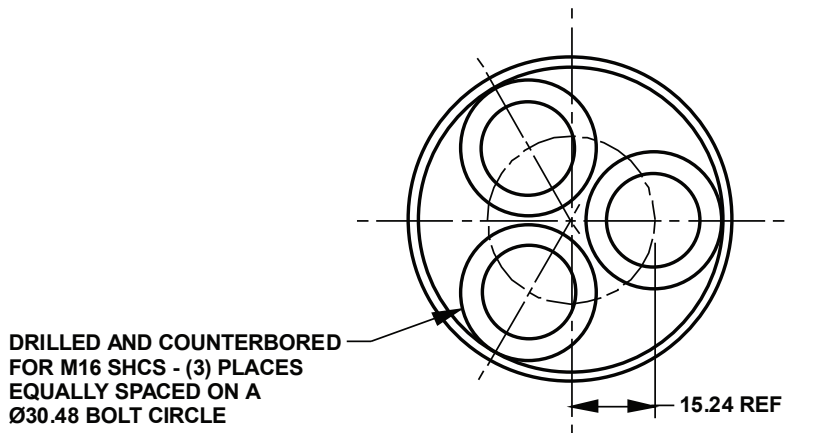

DETAIL C - COLLAR

**MATERIAL: STEEL (MANUFACTURERS CHOICE)**

# Ø50 HD GUIDE KEEPER

(G104 Series)

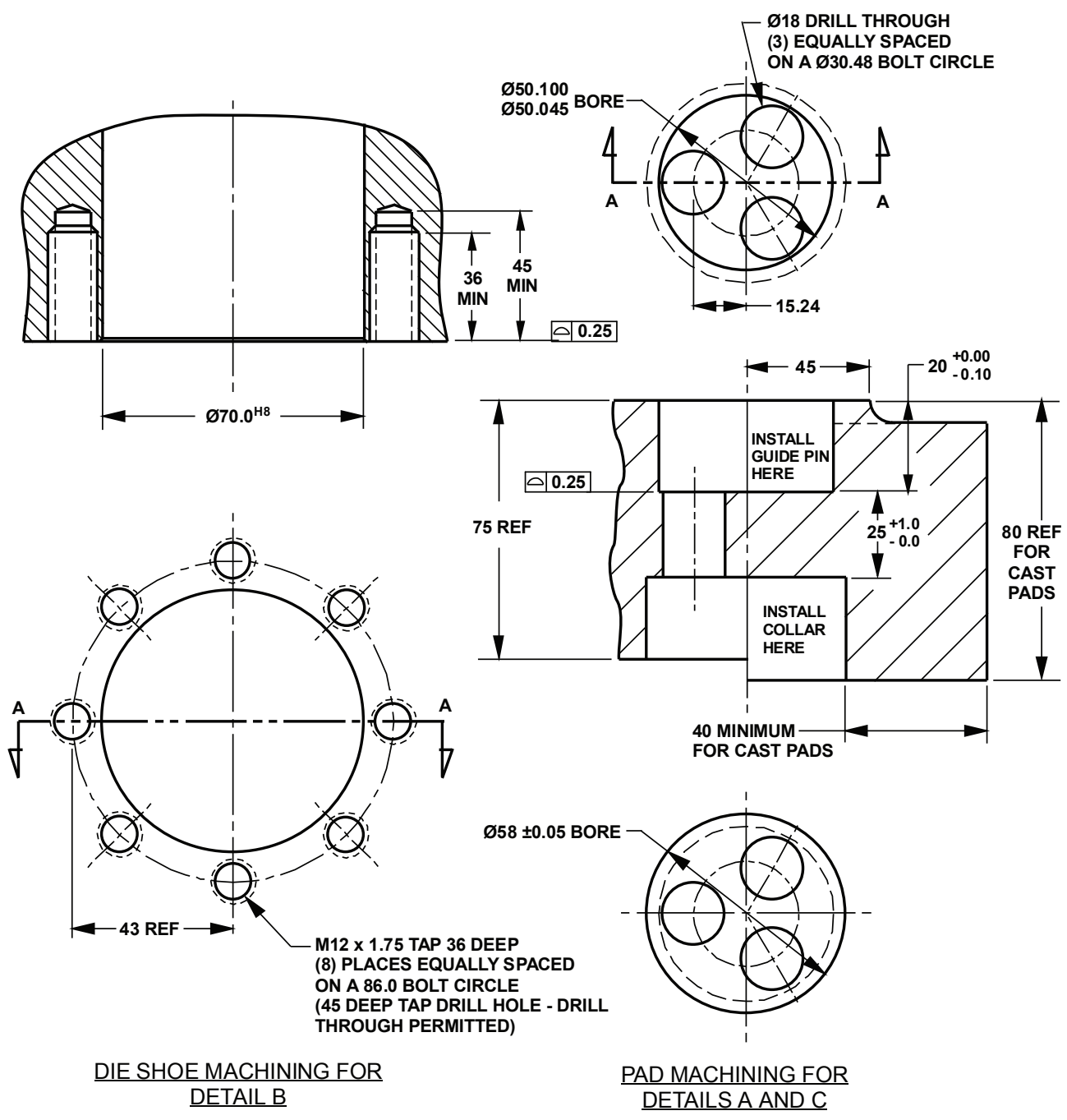

**NOTES & SPECIFICATIONS:**

- Installation information
- Serrated safety washers are recommended.

# Ø36 HD GUIDE KEEPER

(G105 Series)

Stamping

06/24/17

DET.	QUAN.	DESCRIPTION
A	1	GUIDE PIN
B	1	URETHANE DAMPENER
C	1	COLLAR
D	1	BUSHING
E	1	BEARING ASSEMBLY

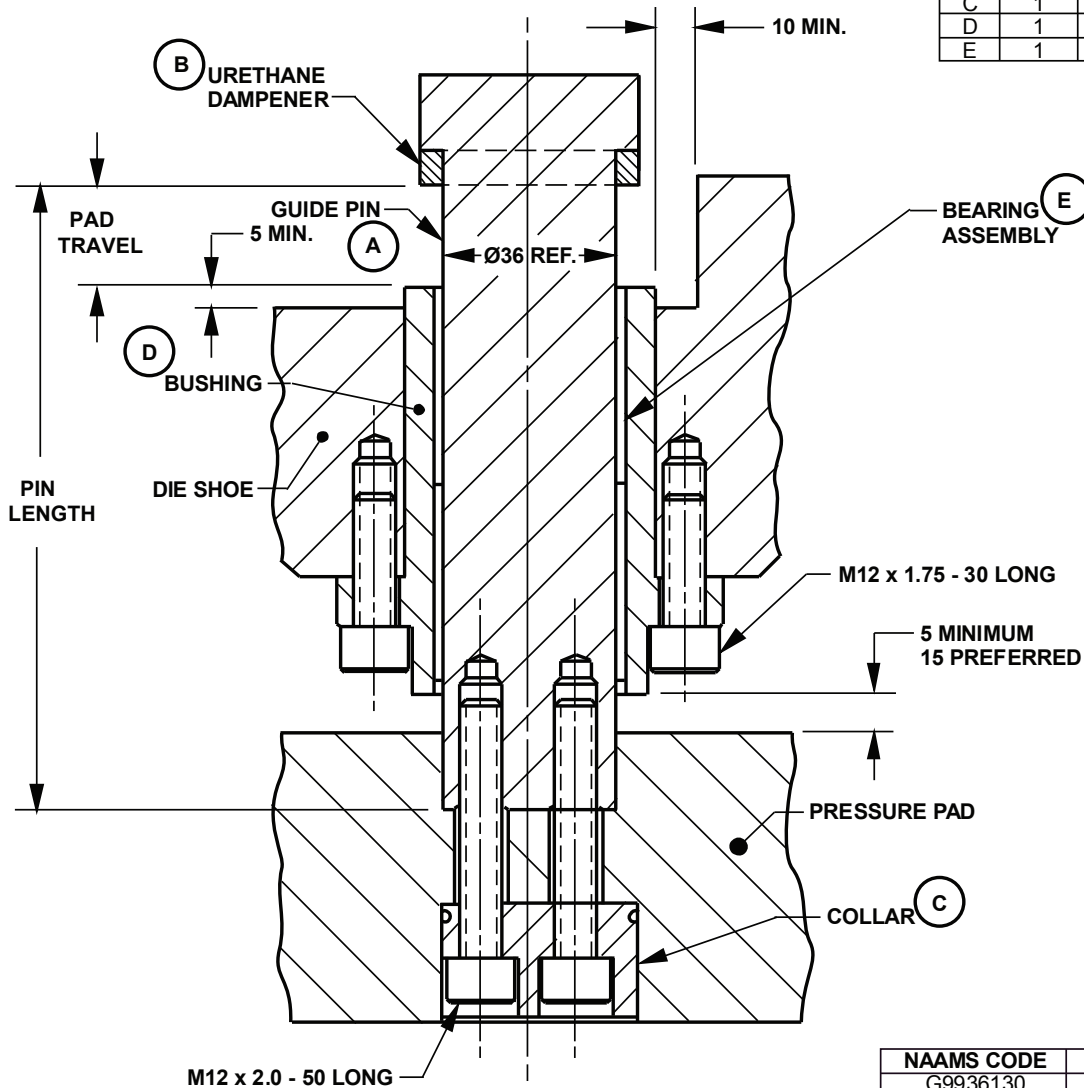

## NOTES & SPECIFICATIONS:

**MATERIAL: STEEL - MANUFACTURERS CHOICE**

- Break all edges.
- Mark with NAAMS order code and manufacturer's logo.
- Refer to manufactures catalog for design information.
- For use in small upper pads with engineering approval only.
- For use in lower pads when G98 series guide keepers will not fit.

NAAMS CODE	PIN LENGTH	PAD TRAVEL
G9936130	130	30
G9936140	140	40
G9936150	150	50
G9936160	160	60
G9936170	170	70
G9936180	180	80
G9936190	190	90
G9936200	200	100
G9936210	210	110
G9936220	220	120

# Ø36 HD GUIDE KEEPER

(G105 Series)

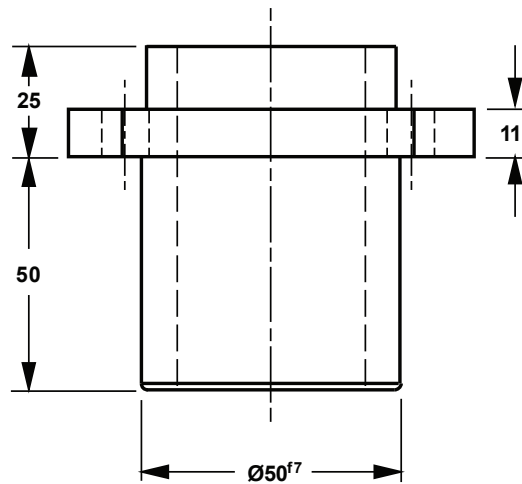
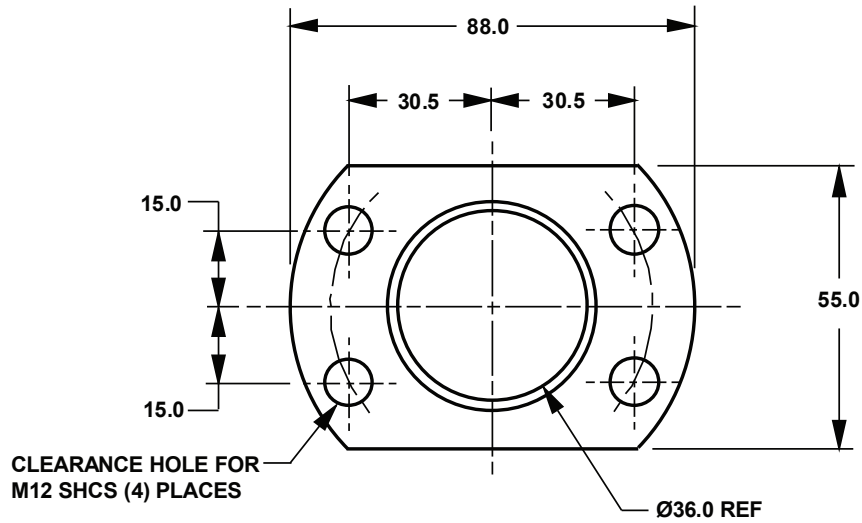

DETAIL A - BUSHING

**MATERIAL: STEEL (MANUFACTURERS CHOICE)**

- 6 - M12 x 1.75 x 30 long grade 12.9 socket head cap screws required for assembly (not supplied).

# Ø36 HD GUIDE KEEPER

(G105 Series)

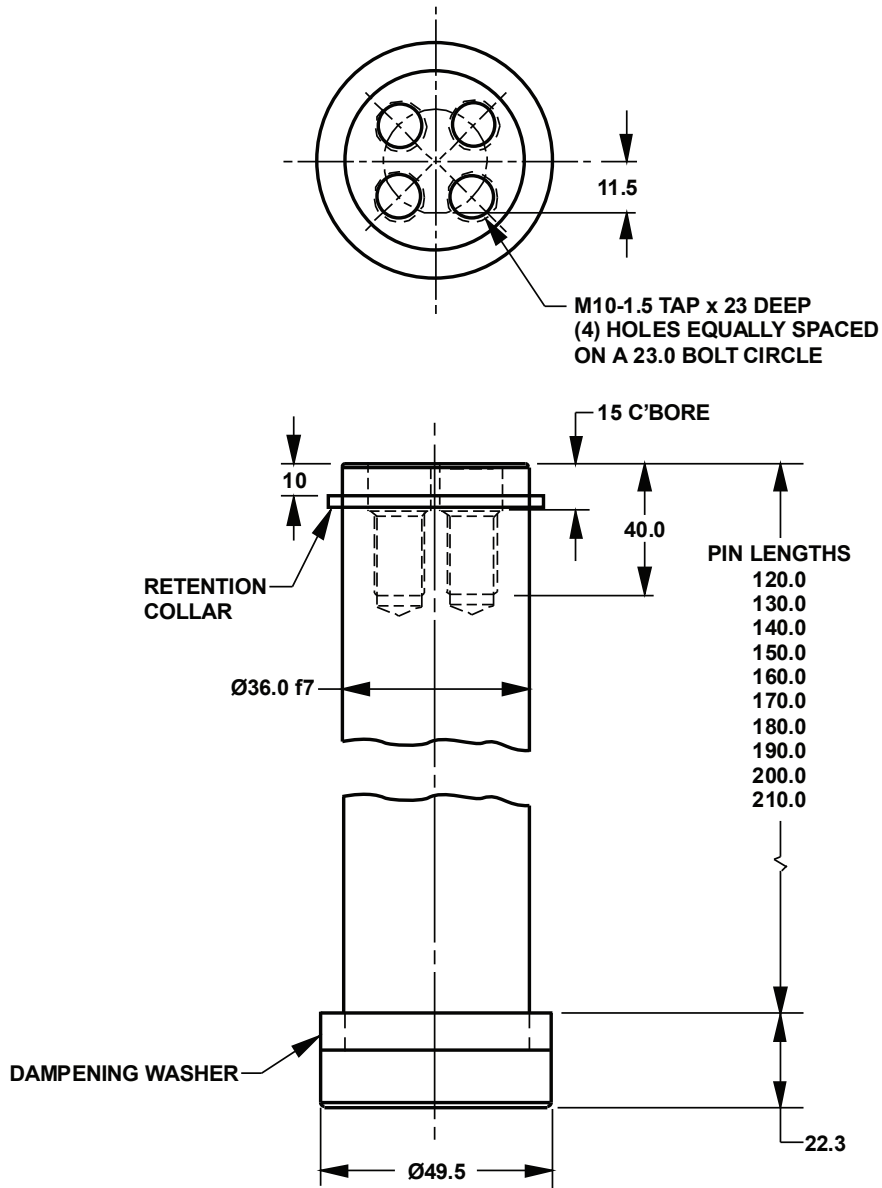

DETAIL B - GUIDE PIN

**MATERIAL: STEEL (MANUFACTURERS CHOICE)**

- For a 75 mm thick steel pad, 3 - M12 x 1.75 x 50 long grade 12.9 socket head cap screws required for assembly (not supplied).

# Ø36 HD GUIDE KEEPER

(G105 Series)

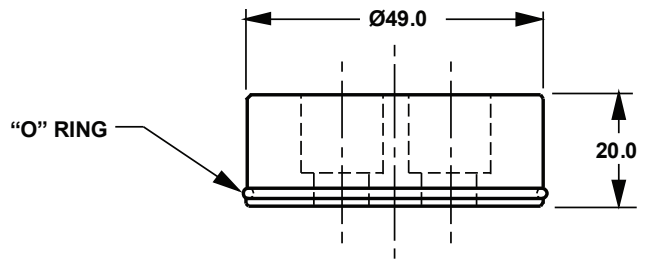
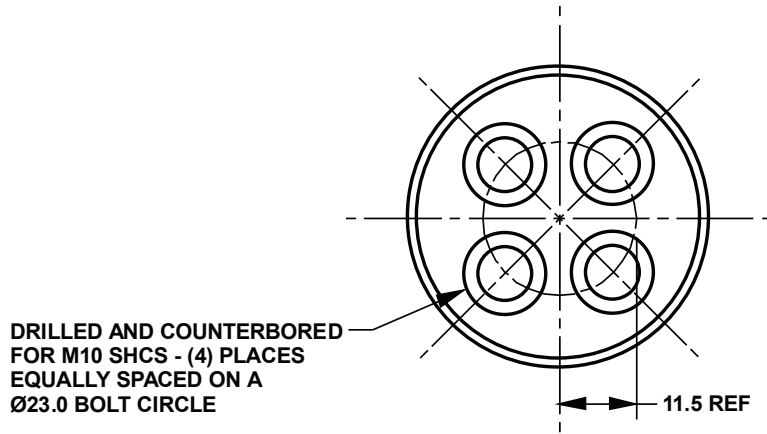

DETAIL C - COLLAR

**MATERIAL: STEEL (MANUFACTURERS CHOICE)**

# Ø36 HD GUIDE KEEPER

(G105 Series)

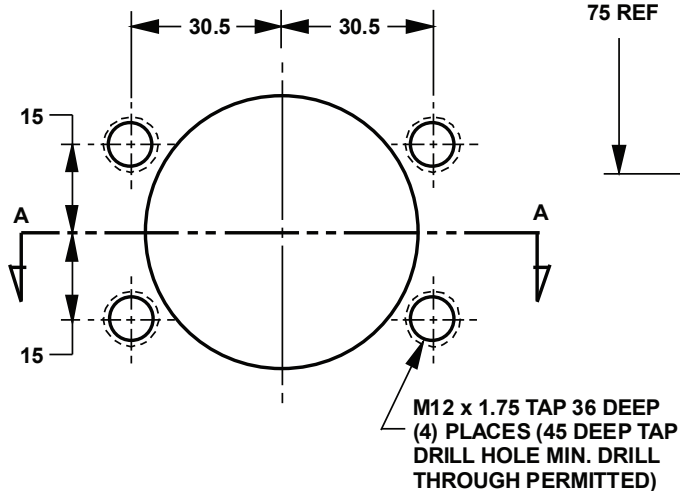
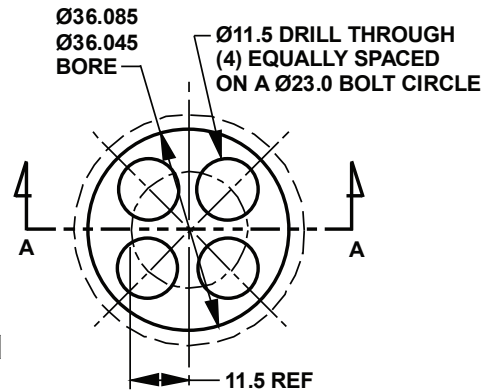
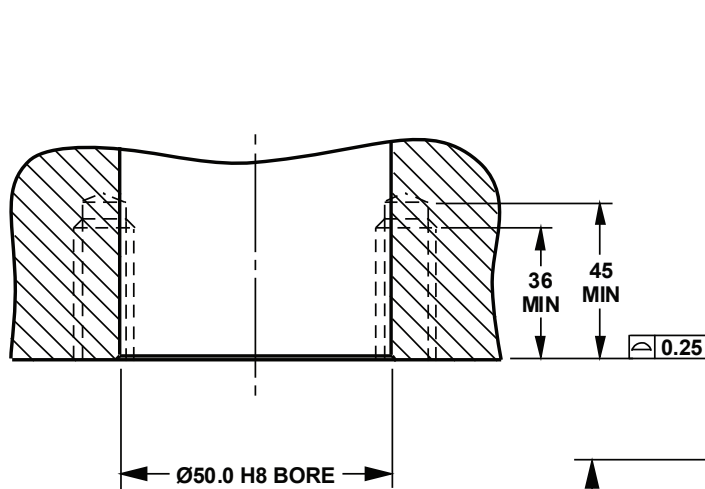

DIE SHOE MACHINING FOR  
 DETAIL B

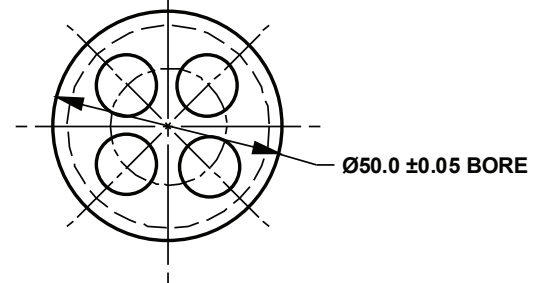
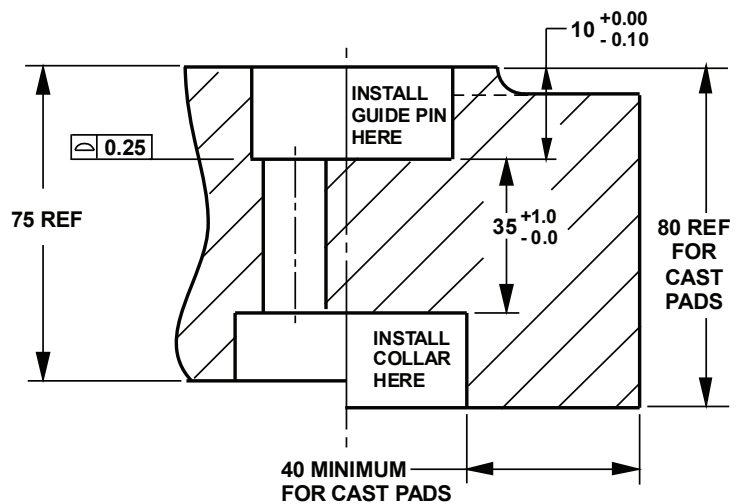

PAD MACHINING FOR  
 DETAILS A AND C

## NOTES & SPECIFICATIONS:

- Installation information
- Serrated safety washers recommended.

# Ø65 HD GUIDE KEEPER

(G106 Series)

Stamping

06/25/17

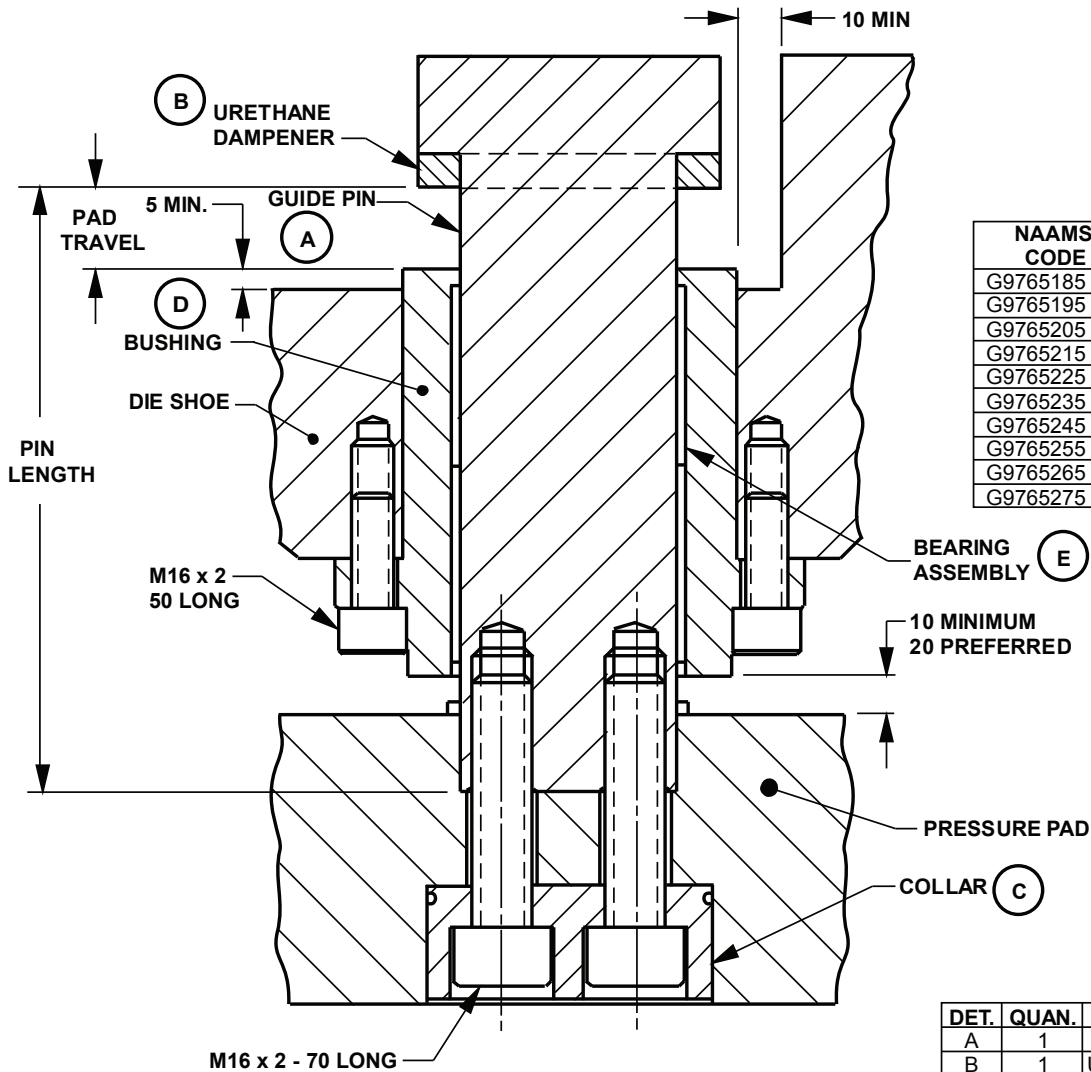

NAAMS CODE	PIN LENGTH	PAD TRAVEL
G9765185	185	25
G9765195	195	35
G9765205	205	45
G9765215	215	55
G9765225	225	65
G9765235	235	75
G9765245	245	85
G9765255	255	95
G9765265	265	105
G9765275	275	115

DET.	QUAN.	DESCRIPTION
A	1	GUIDE PIN
B	1	URETHANE DAMPENER
C	1	COLLAR
D	1	BUSHING
E	1	BEARING ASSEMBLY

## NOTES & SPECIFICATIONS:

**MATERIAL: STEEL - MANUFACTURERS CHOICE**

- Break all edges.
- Mark with NAAMS order code and manufacturer's logo.
- Refer to manufactures catalog for design information.
- For use in upper and lower pads.



# Ø65 HD GUIDE KEEPER

(G106 Series)

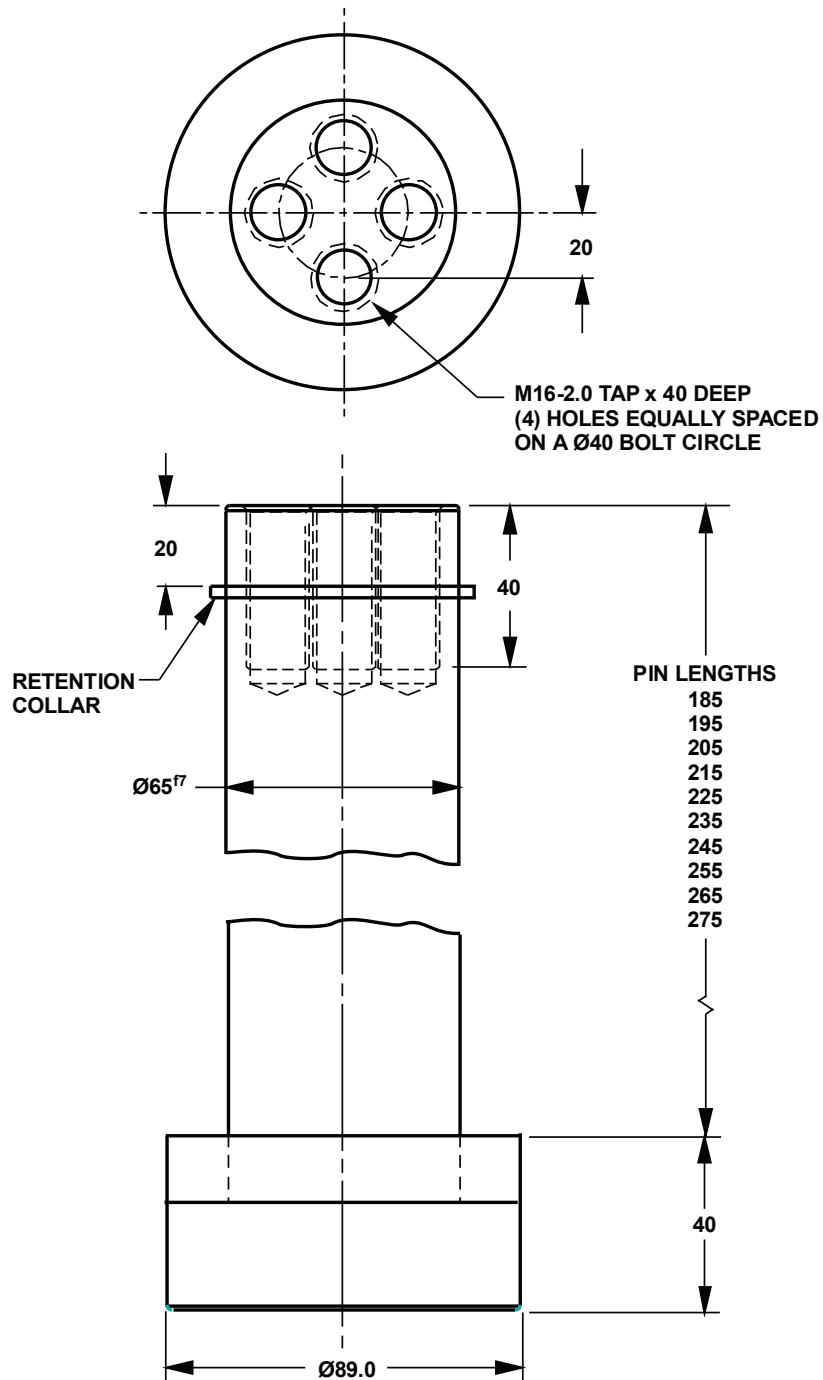

DETAIL A - GUIDE PIN

## NOTES & SPECIFICATIONS:

**MATERIAL: STEEL (MANUFACTURER'S CHOICE)**

- For a 75mm thick steel pad, 3 - M16 x 2.0 x 70 long grade 12.9 socket head cap screws required for assembly (not supplied).

# Ø65 HD GUIDE KEEPER

(G106 Series)

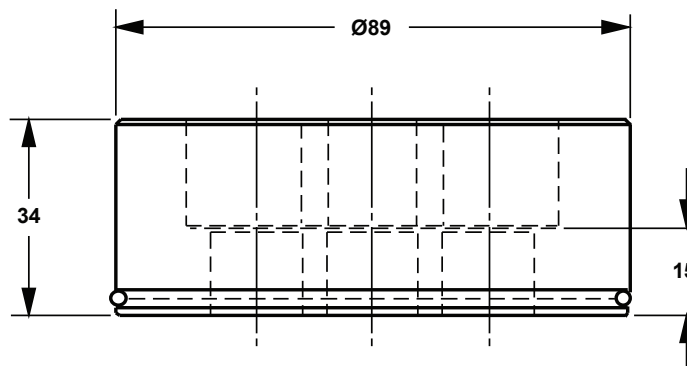
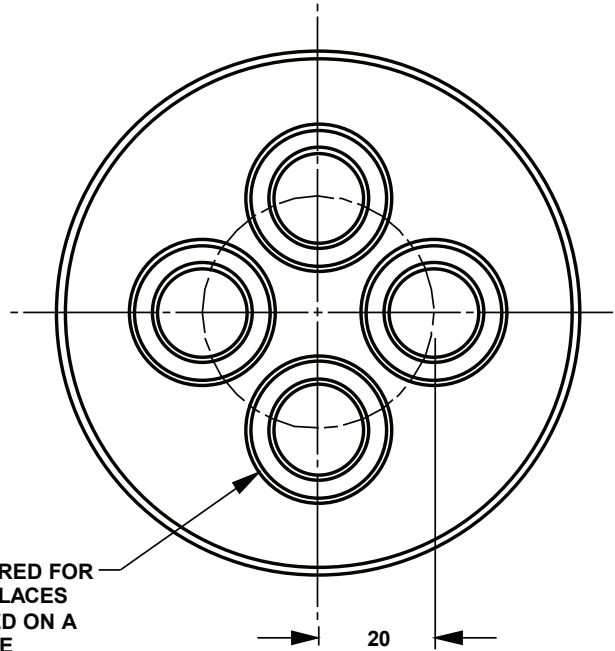

DETAIL C - COLLAR

## NOTES & SPECIFICATIONS:

MATERIAL: STEEL (MANUFACTURER'S CHOICE)

# Ø65 HD GUIDE KEEPER

(G106 Series)

Stamping

06/25/17

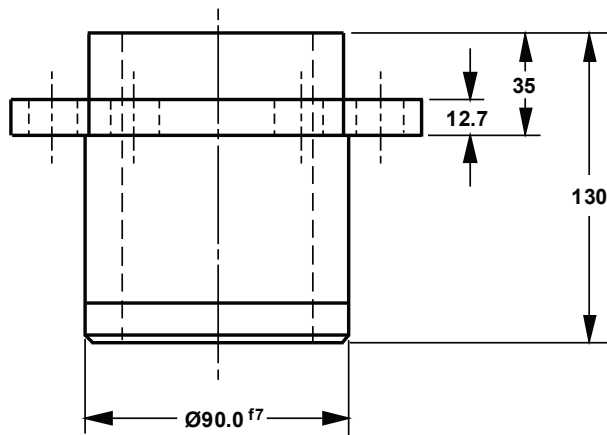
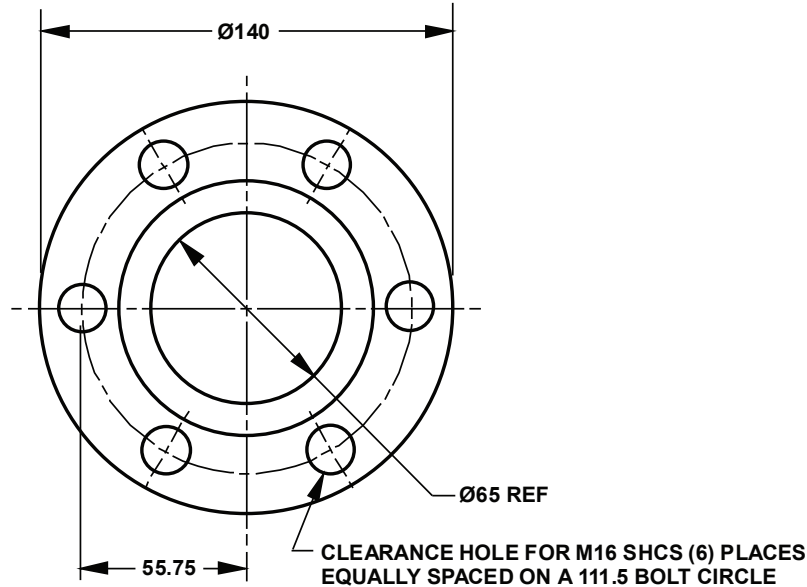

DETAIL D - BUSHING

## NOTES & SPECIFICATIONS:

**MATERIAL: STEEL (MANUFACTURER'S CHOICE)**

- 6 - M16 x 2.0 x 50 long grade 12.9 socket head cap screws required for assembly (not supplied).

# Ø65 HD GUIDE KEEPER

(G106 Series)

Stamping

06/25/17

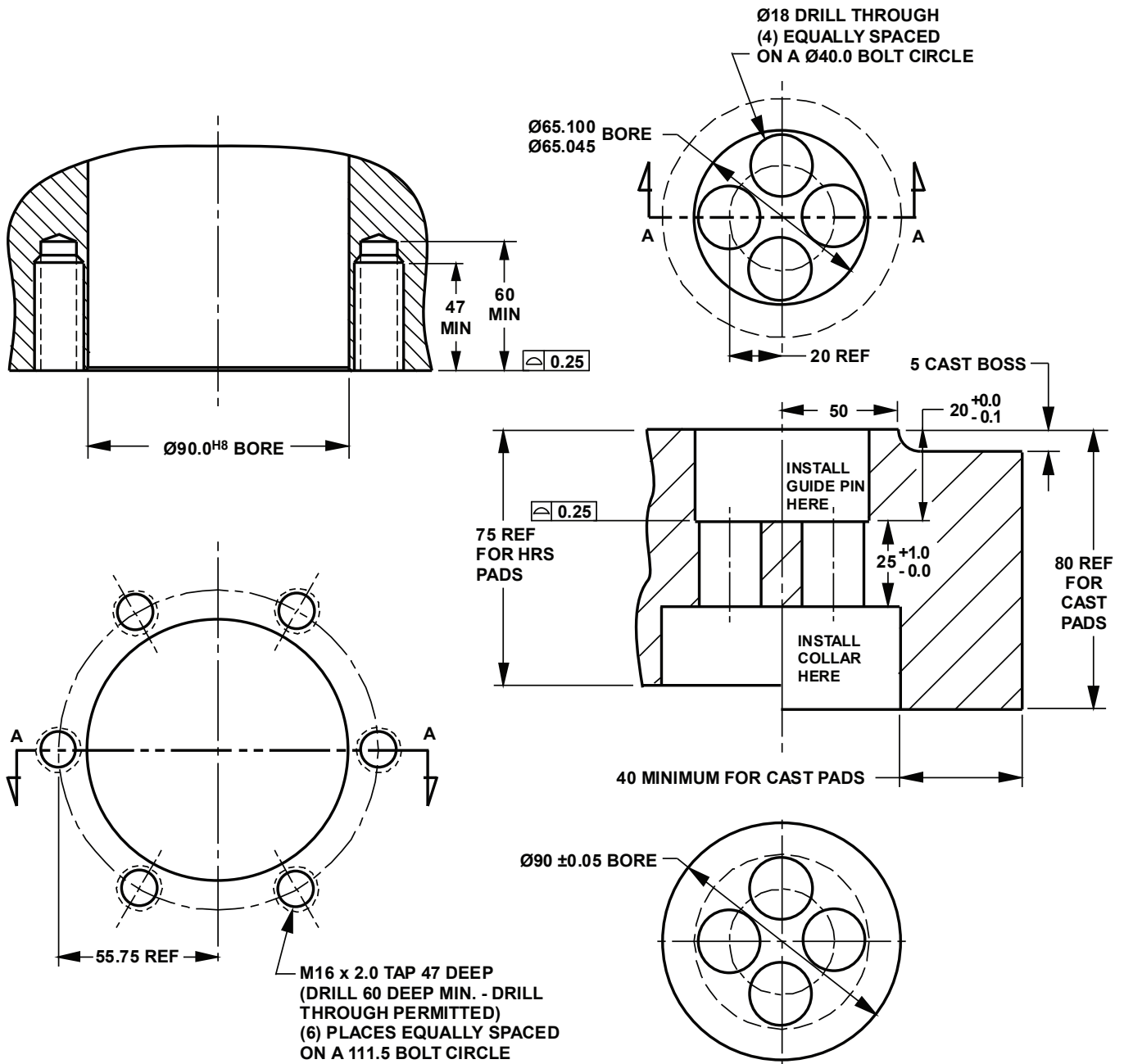

DIE SHOE MACHINING FOR  
 DETAIL B

PAD MACHINING FOR  
 DETAILS A AND C

## NOTES & SPECIFICATIONS:

- Installation information
- Serrated safety washers are recommended.

# PANEL BLANK SUPPORT ASSEMBLY (G107 SERIES)

GLOBAL STANDARD COMPONENTS

TM **NAAMS**



Stamping

03/19/21

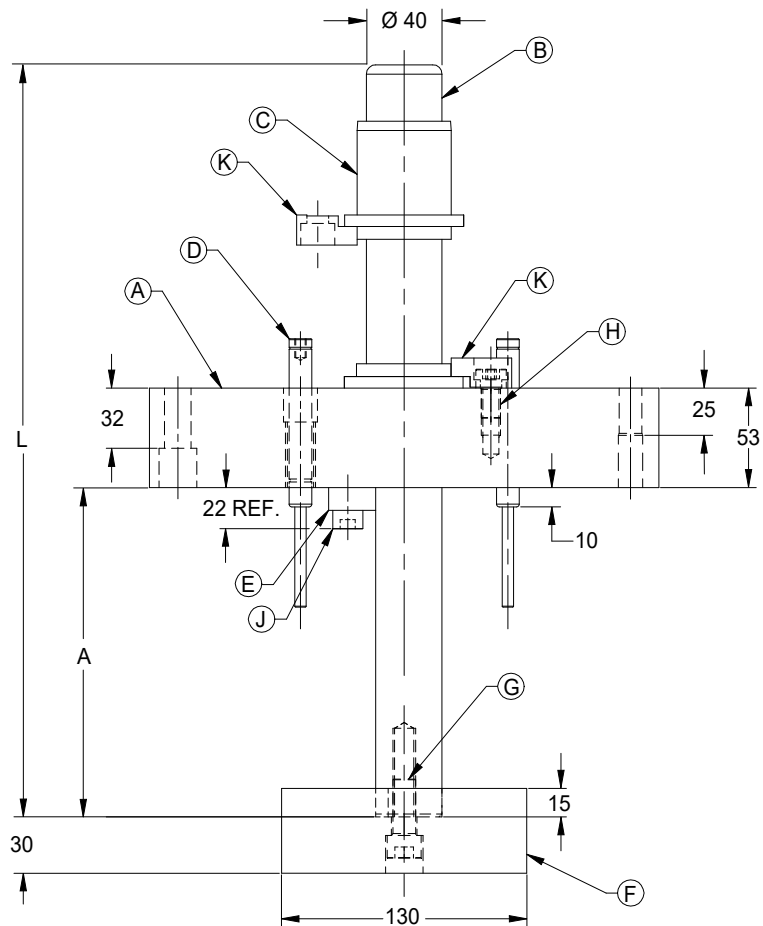
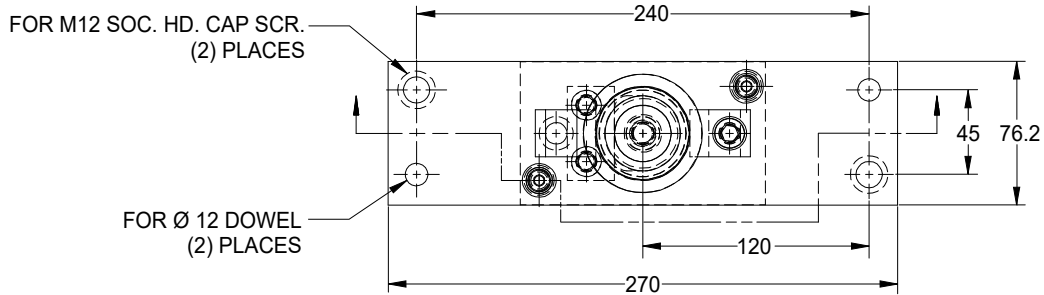

PERMANENTLY MARK EACH PART WITH  
PART NUMBER AND MANUFACTURER'S BRAND  
ORDER ALL DETAILS SEPARATELY

**PANEL BLANK SUPPORT  
ASSEMBLY  
(G107 SERIES)**

ITEM	QTY	NAME	PART NUMBER
A	1	MOUNTING BLOCK	G990100
B	1	BLANK SUPPORT PIN	G990200-L -A
C	2	GUIDE POST BUSHING	G614063
D	2	M16 THREADED BODY NITROGEN GAS SPRING	C.045.050.TB2.BU
E	1	GUIDE / KEEPER BLOCK	G990300
F	2	PUSHER PLATE	G990400
G	1	M12 X 30 LG. SOC. HD. CAP SCREW	F011212
H	1	M10 X 16 LG. SOC. HD. CAP SCREW	F011009
J	2	M10 X 30 LG. SOC. HD. CAP SCREW	F011012
K	2	GUIDE PIN BUSHING TOE CLAMP	G1023225

ORDER ALL DETAILS SEPARATELY

# MOUNTING BLOCK (G107 SERIES)

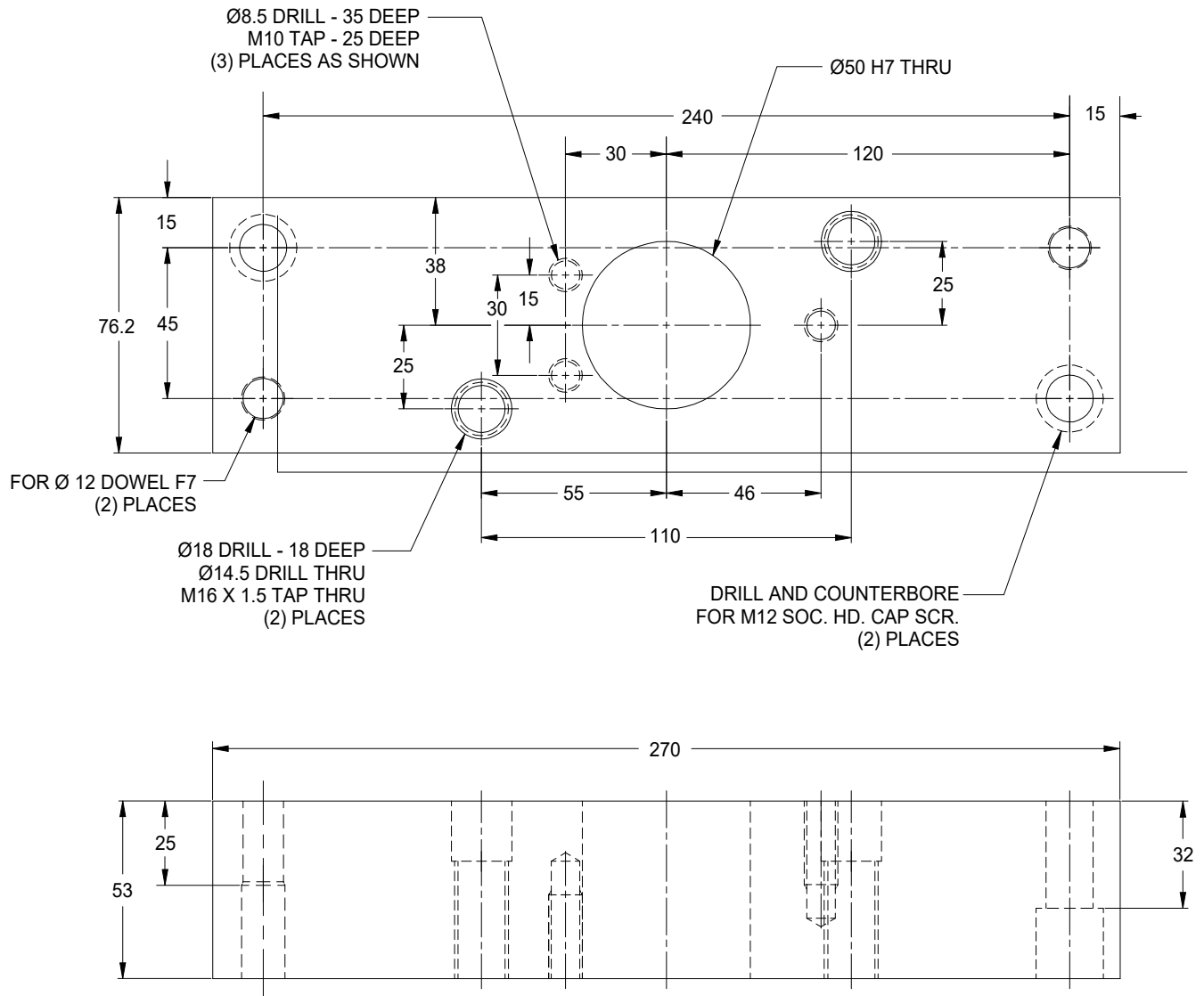

NAAMS CODE  
G990100

MATERIAL: ASTM A-36  
 TOLERANCE BETWEEN SCREW HOLES ±0.25  
 TOLERANCE BETWEEN DOWEL HOLES ±0.01  
 BREAK ALL SHARP CORNERS  
 MARK WITH NAAMS CODE AND MANUFACTURE'S IDENTIFICATION

# BLANK SUPPORT PIN (G107 SERIES)

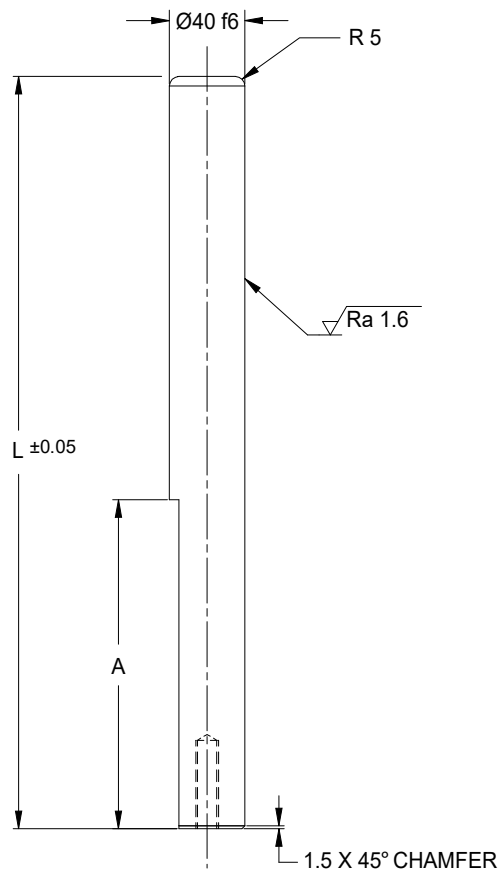
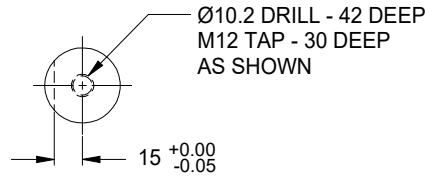

NAAMS CODE  
 G990200-L \_ \_ -A \_ \_  
 "L" LENGTH  
 "A" LENGTH  
 LENGTHS IN 1mm INCREMENTS

MATERIAL: 16 MnCr5 OR AISI 8620 CARBORIZE  
 AND CASE HARDEN TO 57-62 Rc, CASE DEPTH 0.8 mm MIN.  
 MARK TOP END WITH NAAMS CODE AND MANUFACTURE'S IDENTIFICATION



# GUIDE / KEEPER BLOCK (G107 SERIES)

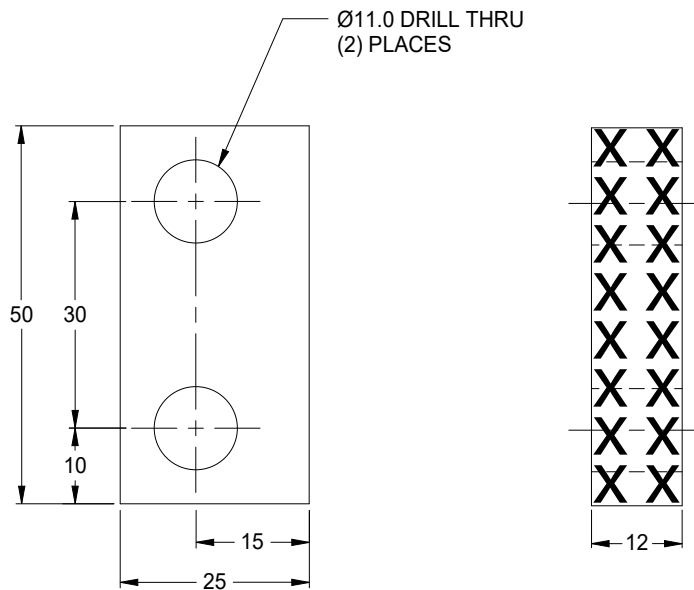

NAAMS CODE  
G990300

MATERIAL: AISI-4150 OR 6150  
CROSS HATCHED AREAS TO BE SURFACE HARDENED.  
CASE DEPTH 0.8 MIN. RC 56-60  
TOLERANCE BETWEEN SCREW HOLES  $\pm 0.12$   
BREAK ALL SHARP EDGES  
MARK WITH NAAMS CODE AND MANUFACTURE'S IDENTIFICATION

# PUSHER PLATE (G107 SERIES)

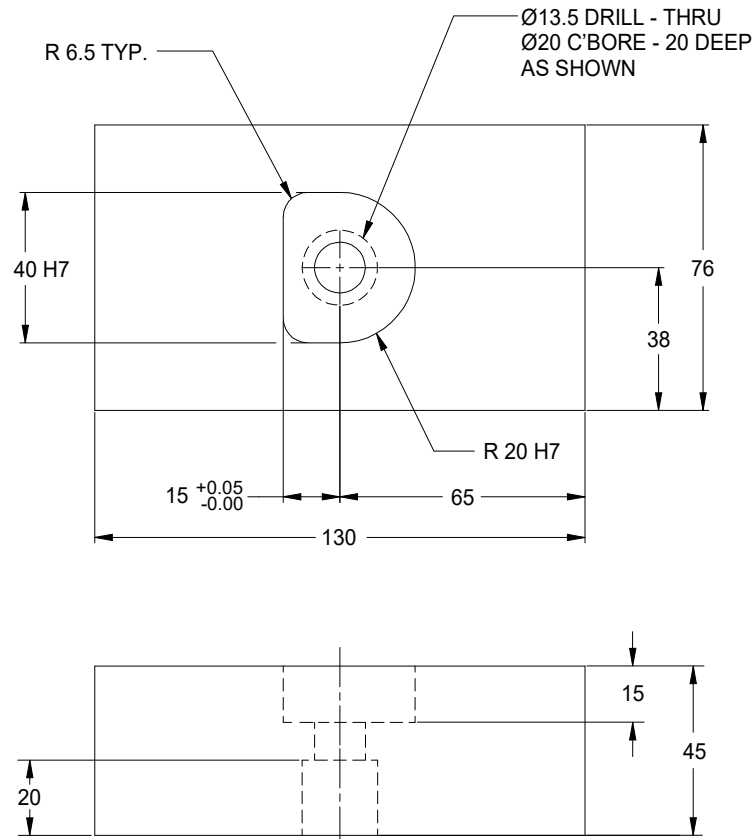

NAAMS CODE  
G990400

MATERIAL: AISI-4150 OR 6150  
BREAK ALL SHARP EDGES  
MARK WITH NAAMS CODE AND MANUFACTURE'S IDENTIFICATION

# SHIM - BALANCE BLOCK

(G108 SERIES)

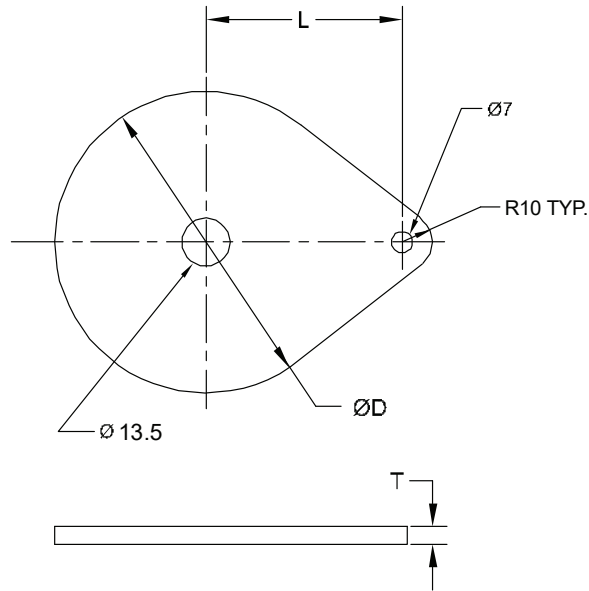

ØD	L	NAAMS CODE	T (THICKNESS)
50	40	G108050N-___	0.05 mm
60	45	G108060N-___	0.10 mm
75	52.5	G108075N-___	0.20 mm
80	55	G108080N-___	0.30 mm
100	65	G108100N-___	0.40 mm
80	47	G108080S-___	0.50 mm
100	57	G108100S-___	

**ORDER EXAMPLE:**

G108 060N - 005  
 SHIM THICKNESS  
 (005=0.05, 010=0.10, ..., 050=0.50)  
 N=Ford & GM S=Stelantis  
 BALANCE BLOCK DIA.

**NOTES & SPECIFICATIONS:**

MATERIAL: ISO X5CrNi 18 10  
 BREAK ALL SHARP EDGES  
 MARK WITH NAAMS CODE AND MANUFACTURE'S IDENTIFICATION

# SHIM - BALANCE BLOCK

(G109 SERIES)

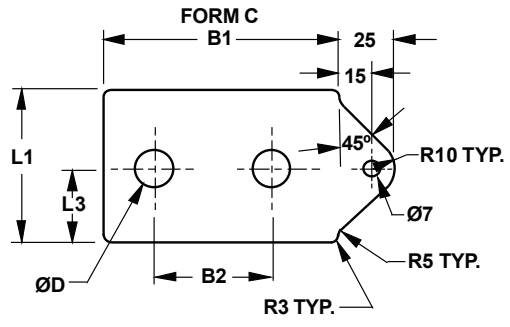
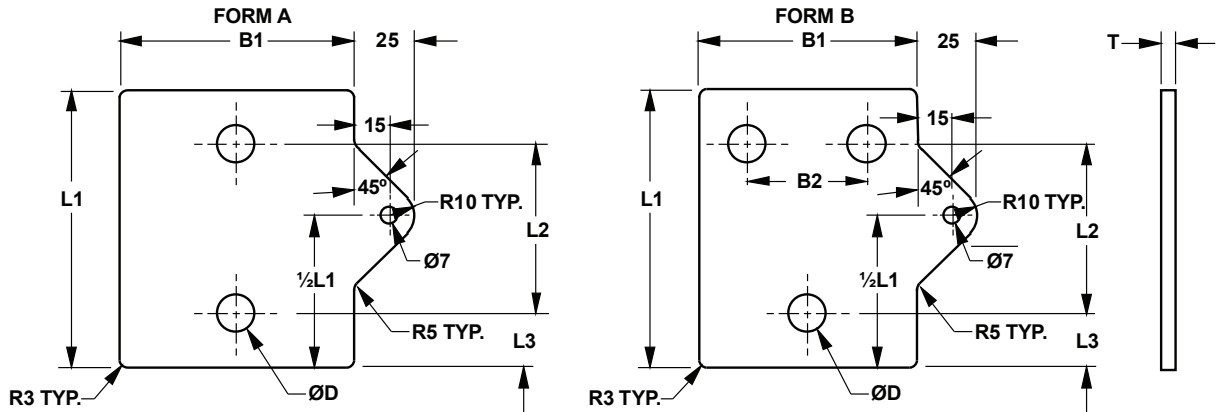

T	THICKNESS
005	0.05mm
010	0.10mm
020	0.20mm
030	0.30mm
040	0.40mm
050	0.50mm

ORDER EXAMPLE:  
 G109 050 125 - 005  
 ——— SHIM THICKNESS (T)  
 (005=0.05, 010=0.10,.....050=0.50)  
 ——— WEAR PLATE LENGTH (L1)  
 ——— WEAR PLATE WIDTH (B1)

**NOTES & SPECIFICATIONS:**

MATERIAL: ISO X5CrNi 18 10  
 BREAK ALL SHARP EDGES  
 MARK WITH NAAMS CODE AND MANUFACTURE'S IDENTIFICATION

# SHIM - BALANCE BLOCK

(G109 SERIES)

B1 ±0.25	L1 ±0.25	FORM	B2 ±0.2	L2 ±0.2	L3 ±0.2	ØD
50	100	A	-	50	25	13.5
	125			75		
	160			110		
	200			150		
80	100	A	-	50	25	
	125			75		
	160			110		
	200			150		
100	50	C	50	-	25	
	80			-	40	
	100	A	-	50	25	
	125			75		
	160			110		
125	200	C	75	150	25	
	80			-		
	100	B		50		
	125			75		
	160			110		
160	200	B	110	150	25	
	100			50		
	125			75		
	160			110		