

# STOP BLOCKS INDEX

PAGE	DATE	NAAMS CODE	DESCRIPTION
<a href="#">L-1</a>	05/25/12		Stop Blocks Index
<a href="#">L-2</a>	05/25/12	ASC018 – ASC091	Stop Blocks Crowned
<a href="#">L-3</a>	05/25/12	ASF018 – ASF091	Stop Blocks Flat
<a href="#">L-4</a>	05/25/12	ASF001	Stop Block Flat
<a href="#">L-5</a>	05/25/12	ASF002	Stop Block Flat

# STOP BLOCKS CROWNED

Tolerances: METRIC

1 PLACE  $\pm 0.3$

2 PLACE  $\pm 0.03$

Identify with NAAMS CODE number as shown **XXX**.

Black Oxide Finish.

MATERIAL: STEEL SAE 1060 – Flame Harden Cross-Hatched  
Surface 3.0 DEEP MIN. Rc 55-60.

SEE PAGE B-1.1 FOR GLOBAL MATERIALS CHART

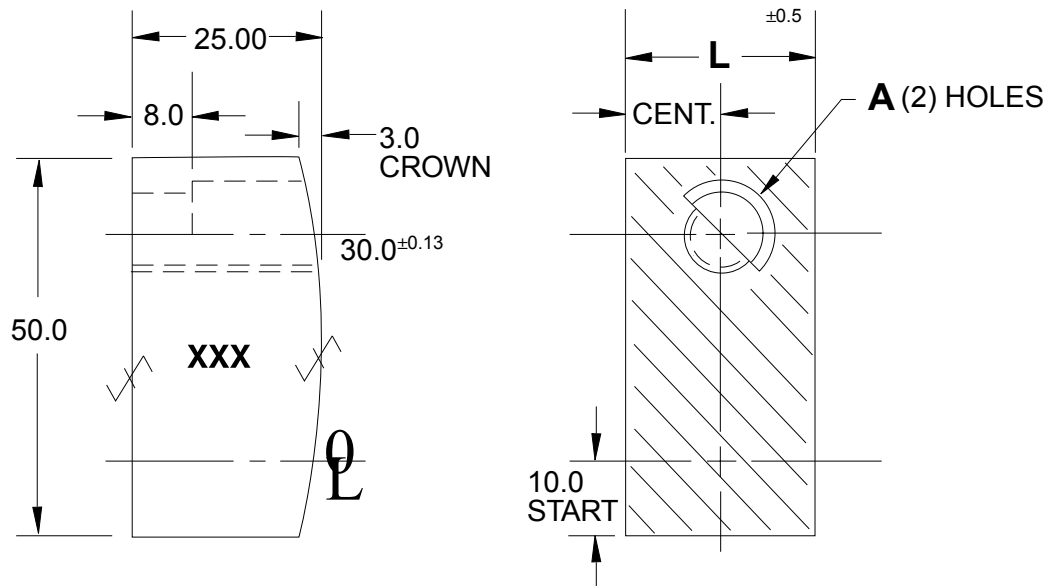

NAAMS CODE	L	A
ASC018	20	Drill & C/Bore for M8 Soc Hd Scr
ASC019	20	M8 x 1.25
ASC020	25	Drill & C/Bore for M10 Soc Hd Scr
ASC021	25	M10 x 1.5
ASC060	60	Drill & C/Bore for M10 Soc Hd Scr
ASC061	60	M10 x 1.5
ASC090	90	Drill & C/Bore for M10 Soc Hd Scr
ASC091	90	M10 x 1.5

A  
B

D

C

# STOP BLOCKS FLAT

GLOBAL STANDARD COMPONENTS



Assembly

05/25/12

Tolerances: METRIC

1 PLACE  $\pm 0.3$

2 PLACE  $\pm 0.03$

Identify with NAAMS CODE number as shown **XXX**.

Black Oxide Finish.

MATERIAL: STEEL SAE 1060 – Flame Harden Cross-Hatched  
Surface 3.0 DEEP MIN. Rc 55-60.

SEE PAGE B-1.1 FOR GLOBAL MATERIALS CHART

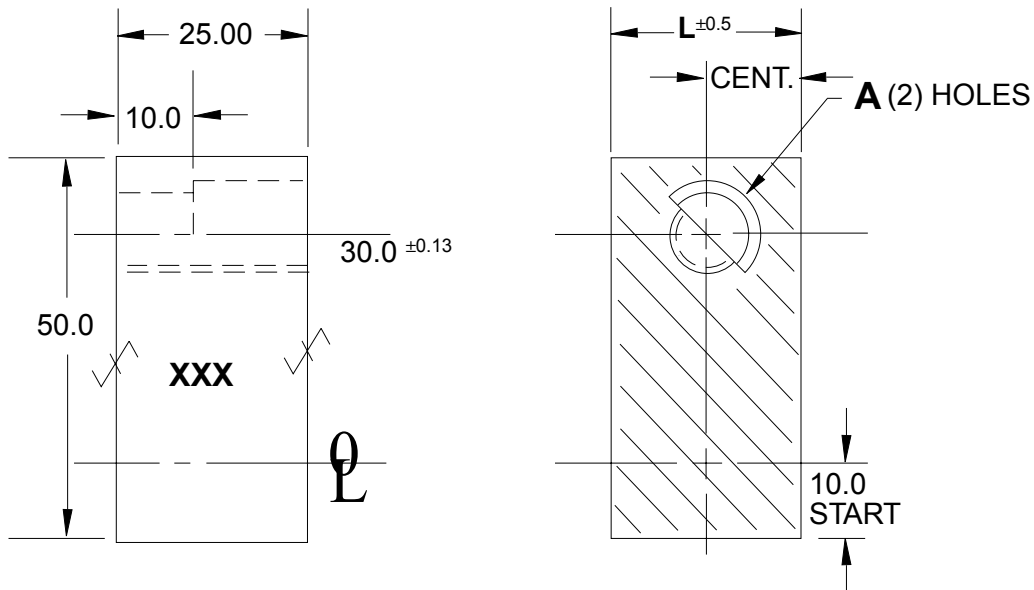

NAAMS CODE	L	A
ASF018	20	Drill & C/Bore for M8 Soc Hd Scr
ASF019	20	M8 x 1.25
ASF020	25	Drill & C/Bore for M10 Soc Hd Scr
ASF021	25	M10 x 1.5
ASF060	60	Drill & C/Bore for M10 Soc Hd Scr
ASF061	60	M10 x 1.5
ASF090	90	Drill & C/Bore for M10 Soc Hd Scr
ASF091	90	M10 x 1.5

A  
C

B

E

D

# STOP BLOCK FLAT ASF001

Tolerances: METRIC

1 PLACE  $\pm 0.3$

2 PLACE  $\pm 0.03$

Identify with NAAMS CODE number as shown **XXX**.

Black Oxide Finish.

MATERIAL: STEEL SAE 1060 – Flame Harden Cross-Hatched  
Surface 3.0 DEEP MIN. Rc 55-60. (Near-Side Only)

SEE PAGE B-1.1 FOR GLOBAL MATERIALS CHART

A

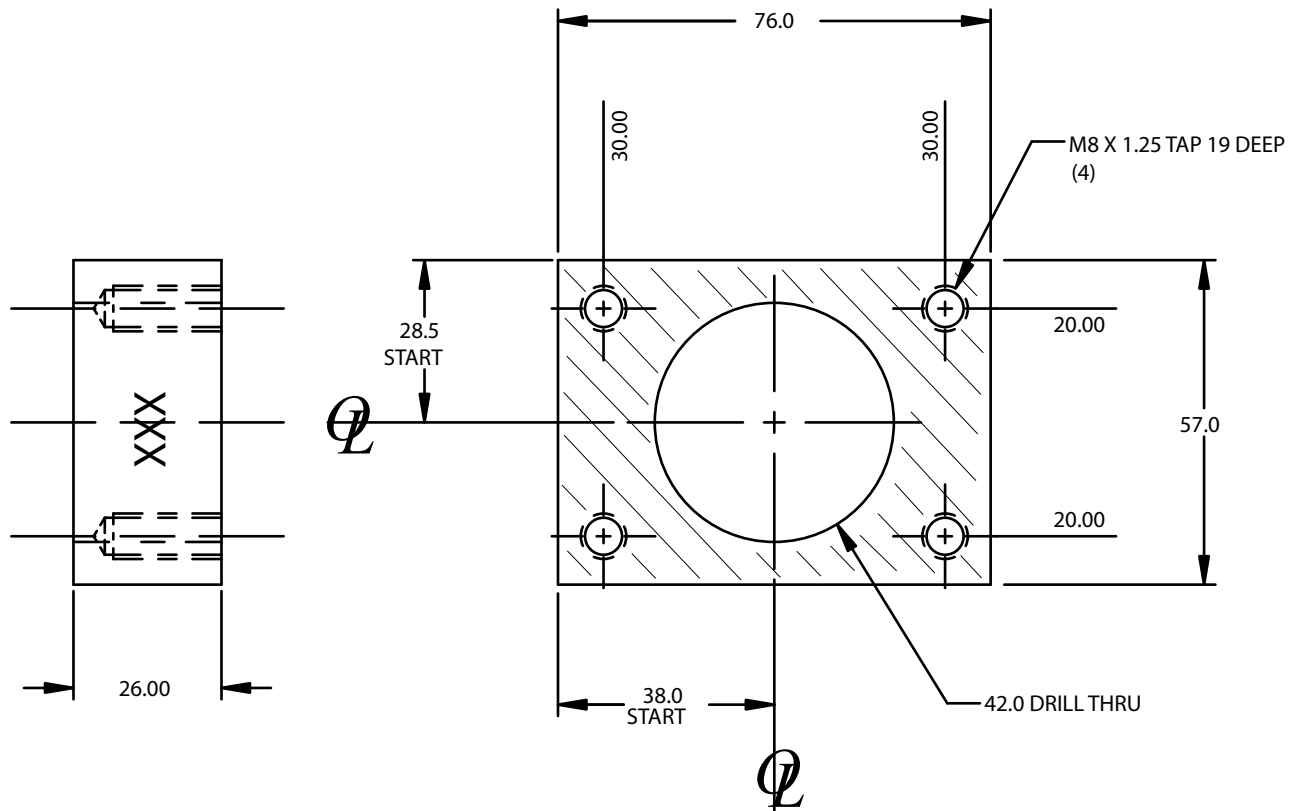

B

# STOP BLOCK FLAT ASF002

Tolerances: METRIC

1 PLACE  $\pm 0.3$

2 PLACE  $\pm 0.03$

Identify with NAAMS CODE number as shown **XXX**.

Black Oxide Finish.

MATERIAL: STEEL SAE 1060 – Flame Harden Cross-Hatched  
 Surface 3.0 DEEP MIN. Rc 55-60. (Far-Side Only)

SEE PAGE B-1.1 FOR GLOBAL MATERIALS CHART

A

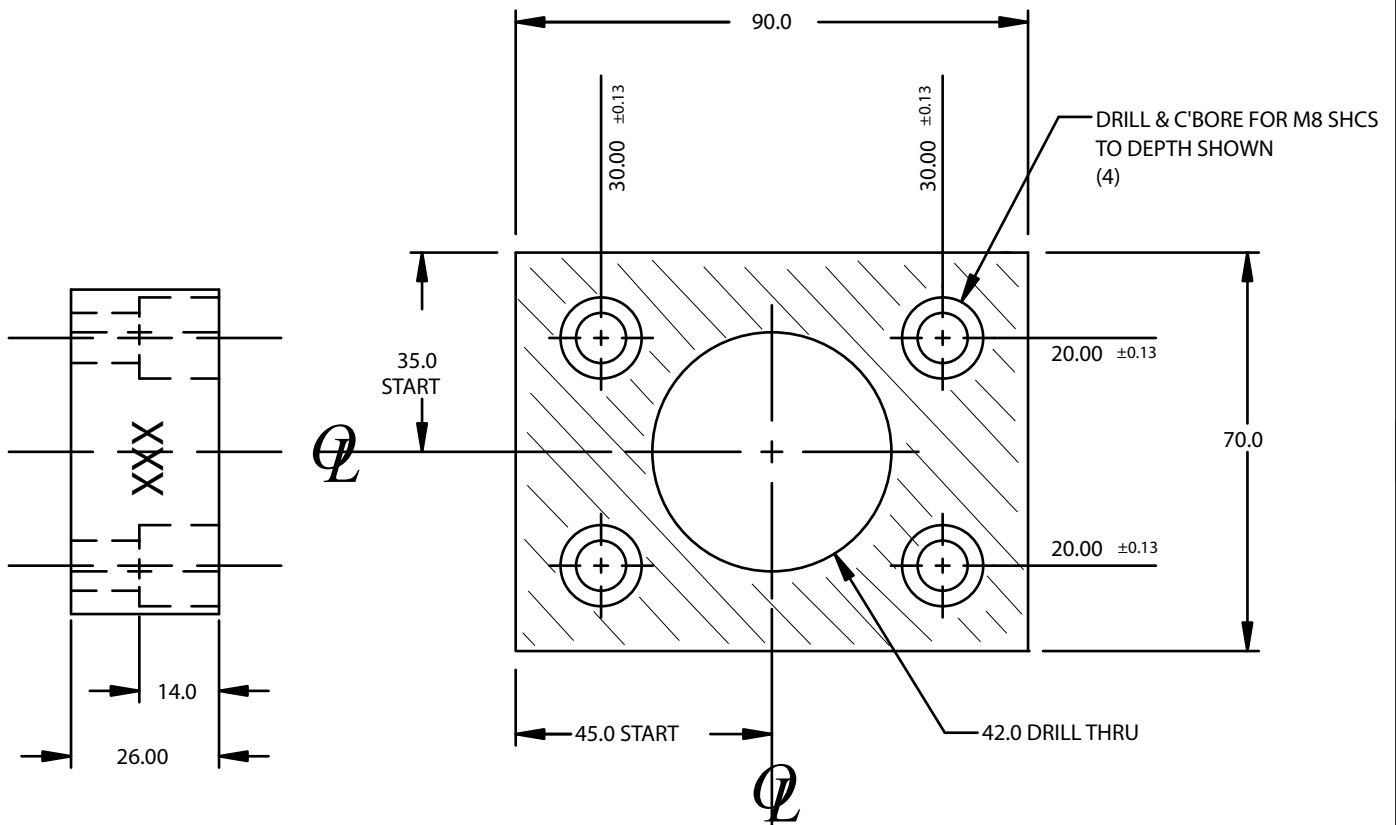

B