

# SHOP FLOOR COMPONENTS INDEX

| PAGE                | DATE     | NAAMS CODE      | DESCRIPTION                    |
|---------------------|----------|-----------------|--------------------------------|
| <a href="#">X-1</a> | 07/09/07 |                 | SHOP FLOOR COMPONENTS<br>INDEX |
| <a href="#">X-2</a> | 07/09/07 | ACB001 - ACB002 | CERTIFICATION BLOCKS           |
| <a href="#">X-3</a> | 07/09/07 | AXB001          | HOSE BRACKET                   |

# CERTIFICATION BLOCKS

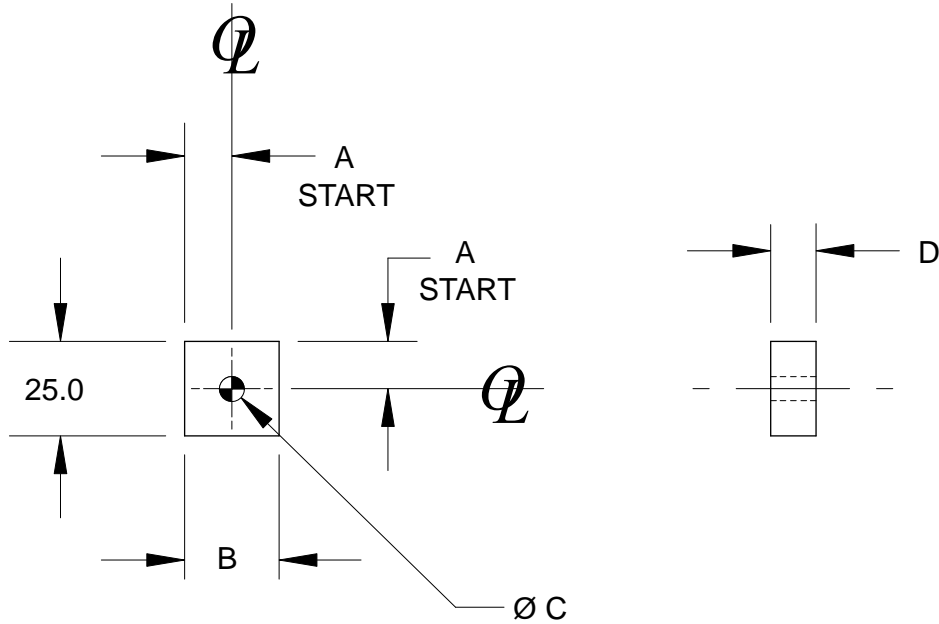

| NAAMS CODE | A      | B      | Ø C                                                                 | D      |
|------------|--------|--------|---------------------------------------------------------------------|--------|
| ACB001     | * 0.50 | * 1.00 | * 0.2500 $\begin{smallmatrix} +0.0005 \\ -0.0000 \end{smallmatrix}$ | * 0.50 |
| ACB002     | 12.5   | 25.0   | 6.00 $\begin{smallmatrix} +0.013 \\ -0.000 \end{smallmatrix}$       | 12.0   |

MAT'L - C.R.S.

STK: 1/2" x 1" x 25.0mm LG (ACB001)

STK: 12mm x 25mm x 25.0mm LG (ACB002)

NOTE: ALL DIMENSIONS ARE METRIC UNLESS NOTED \*.

